

POWER SYSTEM HARMONICS

Second Edition

Jos Arrillaga and Neville R. Watson

University of Canterbury, Christchurch, New Zealand



John Wiley & Sons, Ltd

POWER SYSTEM HARMONICS

POWER SYSTEM HARMONICS

Second Edition

Jos Arrillaga and Neville R. Watson

University of Canterbury, Christchurch, New Zealand



John Wiley & Sons, Ltd

Copyright © 2003

John Wiley & Sons Ltd, The Atrium, Southern Gate, Chichester,
West Sussex PO19 8SQ, England

Telephone (+44) 1243 779777

Email (for orders and customer service enquiries): cs-books@wiley.co.uk

Visit our Home Page on www.wileyurope.com or www.wiley.com

All Rights Reserved. No part of this publication may be reproduced, stored in a retrieval system or transmitted in any form or by any means, electronic, mechanical, photocopying, recording, scanning or otherwise, except under the terms of the Copyright, Designs and Patents Act 1988 or under the terms of a licence issued by the Copyright Licensing Agency Ltd, 90 Tottenham Court Road, London W1T 4LP, UK, without the permission in writing of the Publisher. Requests to the Publisher should be addressed to the Permissions Department, John Wiley & Sons Ltd, The Atrium, Southern Gate, Chichester, West Sussex PO19 8SQ, England, or emailed to permreq@wiley.co.uk, or faxed to (+44) 1243 770620.

This publication is designed to provide accurate and authoritative information in regard to the subject matter covered. It is sold on the understanding that the Publisher is not engaged in rendering professional services. If professional advice or other expert assistance is required, the services of a competent professional should be sought.

Other Wiley Editorial Offices

John Wiley & Sons Inc., 111 River Street, Hoboken, NJ 07030, USA

Jossey-Bass, 989 Market Street, San Francisco, CA 94103-1741, USA

Wiley-VCH Verlag GmbH, Boschstr. 12, D-69469 Weinheim, Germany

John Wiley & Sons Australia Ltd, 33 Park Road, Milton, Queensland 4064, Australia

John Wiley & Sons (Asia) Pte Ltd, 2 Clementi Loop #02-01, Jin Xing Distripark, Singapore 129809

John Wiley & Sons Canada Ltd, 22 Worcester Road, Etobicoke, Ontario, Canada M9W 1L1

Wiley also publishes its books in a variety of electronic formats. Some content that appears in print may not be available in electronic books.

British Library Cataloguing in Publication Data

A catalogue record for this book is available from the British Library

ISBN 0-470-85129-5

Typeset in 10/12pt Times by Laserwords Private Limited, Chennai, India

Printed and bound in Great Britain by Antony Rowe Ltd, Chippenham, Wiltshire

This book is printed on acid-free paper responsibly manufactured from sustainable forestry in which at least two trees are planted for each one used for paper production.

Contents

| | |
|--|-----------|
| Preface | xi |
| 1 Subject Definition and Objectives | 1 |
| 1.1 Introduction | 1 |
| 1.2 The Mechanism of Harmonic Generation | 1 |
| 1.3 Definitions and Standards | 5 |
| 1.3.1 Factors Influencing the Development of Standards | 7 |
| 1.3.2 Existing Harmonic Standards | 8 |
| 1.3.3 General Harmonic Indices | 11 |
| 1.4 Relevance of the Topic | 12 |
| 1.5 References | 15 |
| 2 Harmonic Analysis | 17 |
| 2.1 Introduction | 17 |
| 2.2 Fourier Series and Coefficients | 18 |
| 2.3 Simplifications Resulting from Waveform Symmetry | 20 |
| 2.4 Complex Form of the Fourier Series | 23 |
| 2.5 Convolution of Harmonic Phasors | 25 |
| 2.6 The Fourier Transform | 27 |
| 2.7 Sampled Time Functions | 29 |
| 2.8 Discrete Fourier Transform (DFT) | 30 |
| 2.9 The Nyquist Frequency and Aliasing | 33 |
| 2.10 Fast Fourier Transform (FFT) | 35 |
| 2.11 Window Functions | 38 |
| 2.11.1 The Picket Fence | 40 |
| 2.11.2 Spectral Leakage Reduction | 41 |
| 2.11.3 Choice of Window Function | 41 |
| 2.11.4 Main-Lobe Width Reduction | 44 |
| 2.11.5 Application to Inter-Harmonic Analysis | 45 |
| 2.12 Efficiency of FFT Algorithms | 47 |
| 2.12.1 The Radix-2 FFT | 47 |
| 2.12.2 Mixed-Radix FFT | 48 |
| 2.12.3 Real-Valued FFTs | 49 |
| 2.12.4 Partial FFTs | 50 |

| | | |
|----------|---|-----------|
| 2.13 | Alternative Transforms | 52 |
| 2.13.1 | The Wavelet Transform | 53 |
| 2.13.2 | Automation of Disturbance Recognition | 56 |
| 2.14 | Discussion | 58 |
| 2.15 | References | 58 |
| 3 | Harmonic Sources | 61 |
| 3.1 | Introduction | 61 |
| 3.2 | Transformer Magnetisation Nonlinearities | 62 |
| 3.2.1 | Normal Excitation Characteristics | 62 |
| 3.2.2 | Determination of the Current Waveshape | 62 |
| 3.2.3 | Symmetrical Overexcitation | 63 |
| 3.2.4 | Inrush Current Harmonics | 64 |
| 3.2.5 | D.C. Magnetisation | 65 |
| 3.3 | Rotating Machine Harmonics | 67 |
| 3.3.1 | M.m.f. Distribution of A.C. Windings | 67 |
| 3.3.2 | Three-Phase Winding | 68 |
| 3.3.3 | Slot Harmonics | 69 |
| 3.3.4 | Voltage Harmonics Produced by Synchronous Machines | 70 |
| 3.3.5 | Rotor Saliency Effects | 72 |
| 3.3.6 | Voltage Harmonics Produced by Induction Motors | 73 |
| 3.4 | Distortion Caused by Arcing Devices | 74 |
| 3.4.1 | Electric Arc Furnaces | 74 |
| 3.4.2 | Discharge-Type Lighting | 76 |
| 3.5 | Single-Phase Rectification | 79 |
| 3.5.1 | D.C. Power Supplies | 79 |
| 3.5.2 | Line-Commutated Railway Rectifiers | 82 |
| 3.6 | Three-Phase Current-Source Conversion | 85 |
| 3.6.1 | Basic (Six-Pulse) Configuration | 88 |
| 3.6.2 | Effect of Transformer Connection | 91 |
| 3.6.3 | Twelve-Pulse Related Harmonics | 91 |
| 3.6.4 | Higher-Pulse Configurations | 92 |
| 3.6.5 | Effect of Transformer and System Impedance | 93 |
| 3.6.6 | Direct Voltage Harmonics | 97 |
| 3.6.7 | Imperfect D.C. Voltage Smoothing | 99 |
| 3.6.8 | Half-Controlled Rectification | 104 |
| 3.6.9 | Uncharacteristic Harmonic and Inter-Harmonic Generation | 104 |
| 3.6.10 | Frequency Cross-Modulation in Line-Commutated Converter Systems | 112 |
| 3.7 | Three-Phase Voltage-Source Conversion | 116 |
| 3.7.1 | Multi-Level VSC Configurations | 117 |
| 3.8 | Inverter-Fed A.C. Drives | 119 |
| 3.9 | Thyristor-Controlled Reactors | 126 |
| 3.9.1 | The Static VAR Compensator (SVC) | 126 |
| 3.9.2 | Thyristor-Controlled Series Compensation (TCSC) | 129 |

| | | |
|----------|--|------------|
| 3.10 | Modulated Phase Control | 130 |
| 3.10.1 | The Switching Function Approach | 133 |
| 3.10.2 | Derivation of Input Current Harmonics | 135 |
| 3.11 | A.C. Regulators | 137 |
| 3.11.1 | Single-Phase Full-Wave Controller | 137 |
| 3.11.2 | Integral Cycle Control | 138 |
| 3.12 | Discussion | 140 |
| 3.13 | References | 141 |
| 4 | Effects of Harmonic Distortion | 143 |
| 4.1 | Introduction | 143 |
| 4.2 | Resonances | 143 |
| 4.2.1 | Parallel Resonance | 143 |
| 4.2.2 | Series Resonance | 144 |
| 4.2.3 | Effects of Resonance on System Behaviour | 145 |
| 4.2.4 | Complementary and Composite Resonances | 147 |
| 4.2.5 | Poor Damping | 149 |
| 4.3 | Effects of Harmonics on Rotating Machines | 149 |
| 4.3.1 | Harmonic Losses | 149 |
| 4.3.2 | Harmonic Torques | 151 |
| 4.3.3 | Other Effects | 152 |
| 4.4 | Effect of Harmonics on Static Power Plant | 153 |
| 4.4.1 | Transmission System | 153 |
| 4.4.2 | Transformers | 153 |
| 4.4.3 | Capacitor Banks | 155 |
| 4.5 | Power Assessment with Distorted Waveforms | 156 |
| 4.5.1 | Single-Phase System | 156 |
| 4.5.2 | Three-Phase System | 161 |
| 4.5.3 | Power Factor Under Harmonic Distortion | 166 |
| 4.5.4 | Effect of Harmonics on Measuring Instruments | 168 |
| 4.6 | Harmonic Interference with Ripple Control Systems | 169 |
| 4.7 | Harmonic Interference with Power System Protection | 170 |
| 4.7.1 | Harmonic Problems During Fault Conditions | 170 |
| 4.7.2 | Harmonic Problems Outside Fault Conditions | 171 |
| 4.8 | Effect of Harmonics on Consumer Equipment | 171 |
| 4.9 | Interference with Communications | 172 |
| 4.9.1 | Simple Model of a Telephone Circuit | 173 |
| 4.9.2 | Factors Influencing Interference | 173 |
| 4.9.3 | Coupling to Communication Circuits | 174 |
| 4.9.4 | Effect on Communication Circuits (Susceptiveness) | 177 |
| 4.9.5 | Telephone Circuit Balance to Earth | 184 |
| 4.9.6 | Shielding | 185 |
| 4.9.7 | Mitigation Techniques | 186 |
| 4.10 | Audible Noise from Electric Motors | 187 |
| 4.11 | Discussion | 187 |
| | References | 187 |

| | |
|--|------------|
| 5 Harmonic Monitoring | 191 |
| 5.1 Introduction | 191 |
| 5.2 Measurement Requirements | 191 |
| 5.2.1 The IEC 61000 4-7 Document | 191 |
| 5.2.2 Inter-Harmonics | 193 |
| 5.2.3 Harmonic Phase-Angle Displacement | 194 |
| 5.2.4 Harmonic Symmetrical Components | 195 |
| 5.3 Transducers | 195 |
| 5.3.1 Current Transformers | 195 |
| 5.3.2 Voltage Transformers | 197 |
| 5.4 Harmonic Instrumentation | 200 |
| 5.4.1 Digital Instrumentation | 202 |
| 5.4.2 Structure of a Modern Monitoring System | 205 |
| 5.5 Data Transmission | 206 |
| 5.6 Presentation of Harmonic Information | 207 |
| 5.7 Examples of Application | 210 |
| 5.7.1 Synchronised Tests | 210 |
| 5.7.2 Group-Connected HVD.C. Converter Test | 215 |
| 5.8 Discussion | 217 |
| 5.9 References | 217 |
| | |
| 6 Harmonic Elimination | 219 |
| 6.1 Introduction | 219 |
| 6.2 Passive Filter Definitions | 219 |
| 6.3 Filter Design Criteria | 221 |
| 6.3.1 Conventional Criteria | 221 |
| 6.3.2 Advanced Filter Design Criteria | 222 |
| 6.4 Network Impedance for Performance Calculations | 223 |
| 6.4.1 Size of System Representation | 223 |
| 6.4.2 Effect of A.C. Network Resistance at Low Frequencies | 224 |
| 6.4.3 Impedance Envelope Diagrams | 225 |
| 6.5 Tuned Filters | 228 |
| 6.5.1 Graphic Approach | 231 |
| 6.5.2 Double-Tuned Filters | 233 |
| 6.5.3 Automatically Tuned Filters | 234 |
| 6.6 Damped Filters | 235 |
| 6.6.1 Types of Damped Filters | 236 |
| 6.6.2 Design of Damped Filters | 236 |
| 6.7 Conventional Filter Configurations | 237 |
| 6.7.1 Six-Pulse Design | 237 |
| 6.7.2 Twelve-Pulse Configuration | 242 |
| 6.8 Band-Pass Filtering for Twelve-Pulse Converters | 242 |
| 6.9 Distribution System Filter Planning | 245 |
| 6.10 Filter Component Properties | 246 |
| 6.10.1 Capacitors | 246 |
| 6.10.2 Inductors | 247 |

| | |
|--|------------|
| 6.11 Filter Costs | 247 |
| 6.11.1 Single-Tuned Filter | 248 |
| 6.11.2 Band-Pass Filter | 250 |
| 6.12 D.C. Side Filters | 253 |
| 6.13 Active Filters | 255 |
| 6.13.1 Series Connection of Active Filters | 256 |
| 6.13.2 Shunt Connection of Active Filters | 257 |
| 6.14 Discussion | 259 |
| 6.15 References | 259 |
| | |
| 7 Computation of Harmonic Flows | 261 |
| 7.1 Introduction | 261 |
| 7.2 Direct Harmonic Analysis | 261 |
| 7.2.1 Frequency Scan Analysis | 264 |
| 7.2.2 Incorporation of Harmonic Voltage Sources | 264 |
| 7.2.3 Cascading Sections | 265 |
| 7.3 Derivation of Network Harmonic Impedances from Field Tests | 266 |
| 7.3.1 Use of Existing Sources (Online Non-Invasive Tests) | 266 |
| 7.3.2 Direct Injection (Online Invasive Tests) | 268 |
| 7.3.3 From Transient Waveforms (Online Non-Invasive Tests) | 268 |
| 7.4 Transmission Line Models | 269 |
| 7.4.1 Mutually Coupled Three-Phase Lines | 273 |
| 7.4.2 Consideration of Terminal Connections | 276 |
| 7.4.3 Equivalent PI Model | 277 |
| 7.4.4 Evaluation of Transmission Line Parameters | 282 |
| 7.5 Underground and Submarine Cables | 286 |
| 7.6 Three-Phase Transformer Models | 290 |
| 7.7 Generator Modelling | 295 |
| 7.8 Shunt Elements | 295 |
| 7.9 Series Elements | 297 |
| 7.10 Distribution System Modelling | 298 |
| 7.11 Load Models | 299 |
| 7.11.1 Induction Motor Model | 302 |
| 7.11.2 Norton Equivalents of Residential Loads | 303 |
| 7.11.3 Empirical Models Based on Measurements | 304 |
| 7.12 Computer Implementation | 304 |
| 7.12.1 Harmonic Penetration Overview | 305 |
| 7.12.2 An Advanced Program Structure | 305 |
| 7.12.3 Data Structure | 307 |
| 7.13 Examples of Application of the Models | 311 |
| 7.13.1 Harmonic Flow in a Homogeneous Transmission Line | 311 |
| 7.13.2 Impedance Loci | 318 |
| 7.13.3 Harmonic Analysis of Transmission Line with Transpositions | 326 |

| | |
|---|------------|
| 7.13.4 Harmonic Analysis of Transmission Line with VAR Compensation | 334 |
| 7.13.5 Harmonic Analysis of an HVD.C. Transmission Line | 335 |
| 7.14 Simulation Backed by Field Tests | 344 |
| 7.14.1 Post-Processing of Transmission Line Harmonics for Test Result Comparisons | 346 |
| 7.15 Discussion | 347 |
| 7.16 References | 348 |
| 8 Advanced Harmonic Assessment | 351 |
| 8.1 Introduction | 351 |
| 8.2 Transfer Function Model | 351 |
| 8.3 Iterative Harmonic Analysis (IHA) | 353 |
| 8.3.1 Fixed-Point Iterative Method | 353 |
| 8.3.2 The Method of Norton Equivalents | 354 |
| 8.3.3 Hybrid Time/Frequency Domain Solution | 354 |
| 8.3.4 The Harmonic Domain | 356 |
| 8.4 Harmonic Power Flow | 359 |
| 8.4.1 Components of a Three-Phase Newton HPF Solution | 360 |
| 8.5 Harmonic State Estimation | 365 |
| 8.5.1 Load and Harmonic Source Identification | 368 |
| 8.6 The Electromagnetic Transients Solution | 369 |
| 8.6.1 Time Step Selection | 370 |
| 8.6.2 A.C. System Representation | 370 |
| 8.6.3 Frequency-Dependent Network Equivalents | 370 |
| 8.6.4 Case Study | 371 |
| 8.7 Discussion on Advanced Harmonic Modelling | 387 |
| 8.8 References | 388 |
| Index | 391 |

Preface

Following the first international conference on Power System Harmonics held in Manchester in 1982, J. Arrillaga was commissioned by John Wiley & Sons to prepare a book on the subject. The book, co-authored by D.A. Bradley and P.S. Bodger and published in 1985, has provided the basis for a variety of courses and workshops on power quality issues. It has also been of considerable assistance to power system designers.

In the past two decades other books and an innumerable number of publications have appeared in the technical literature on the general topic of harmonics. Wiley has probably been the main contributor, with three further books, *Power System Harmonic Analysis* and *Power System Quality Assessment* (both by J. Arrillaga and his colleagues) and *Power System Harmonics Computer Modelling and Analysis* (by E. Acha and M. Madrigal). All these, however, have mostly included material coming out of academic research and on computer simulation techniques. In North America the subject is currently offered in the form of an IEEE CD-ROM tutorial course (*Modelling and Simulation of Power System Harmonics*) and an IEEE (5-hour) videotape on *Power System Harmonics*.

In recent years there have been numerous requests for an update of our original text, maintaining the practical approach to the subject. Therefore the scope of this new edition is not particularly different from the original, namely to provide a general understanding of power system harmonics generation, their effects, monitoring, analysis and elimination, but taking into account the main developments (particularly in power electronics) accepted by the power industry in the past two decades.

It is impractical for most users to develop their own harmonic assessment programs. Thus the analysis sections of the book provide basic understanding of the techniques involved in harmonic assessment and rely on existing available software, with special emphasis on generally available programs such as EMTP and MATLAB. The only exception is an advanced and complex frequency-domain program developed by the authors, called The Harmonic Domain, which is provided in CD-ROM form for demonstration purposes.

We would like to acknowledge the contributions made to the development of this book by many of our colleagues, and in particular by P.S. Bodger, D.A. Bradley, G. Bathurst, S. Chen, A.R. Wood, B.C. Smith, E. Acha, J.F. Eggleston, G. Heydt, A. Medina, M.L. Viana Lisboa, S. Round, A. Semlyen, R. Yacamini and J.D. Ainsworth.

**Jos Arrillaga
Neville Watson**

1

Subject Definition and Objectives

1.1 Introduction

When an electrical signal is sent to an oscilloscope its waveform is observed in the time domain; that is, the screen shows the signal amplitude at each instant in time. If the same signal is applied to a hi-fi amplifier, the resulting sound is a mix of harmonic frequencies that constitute a complete musical chord. The electrical signal, therefore, can be described either by time-domain or frequency-domain information. This book describes the relationships between these two domains in the power system environment, the causes and effects of waveform distortion and the techniques currently available for their measurement, modelling and control.

Reducing voltage and current waveform distortion to acceptable levels has been a problem in power system design from the early days of alternating current. The recent growing concern results from the increasing use of power electronic devices and of waveform-sensitive load equipment.

The utilisation of electrical energy is relying more on the supply of power with controllable frequencies and voltages, while its generation and transmission take place at nominally constant levels. The discrepancy, therefore, requires some form of power conditioning or conversion, normally implemented by power electronic circuitry that distorts the voltage and current waveforms.

The behaviour of circuits undergoing frequent topological changes that distort the waveforms can not be described by the traditional single-frequency phasor theory. In these cases the steady state results from a periodic succession of transient states that require dynamic simulation. However, on the assumption of reasonable periods of steady-state behaviour, the voltage and current waveforms comply with the requirements permitting Fourier analysis [1], and can, therefore, be expressed in terms of harmonic components. A harmonic is defined as the content of the function whose frequency is an integer multiple of the system fundamental frequency.

1.2 The Mechanism of Harmonic Generation

Electricity generation is normally produced at constant frequencies of 50 Hz or 60 Hz and the generators' e.m.f. can be considered practically sinusoidal. However, when

a source of sinusoidal voltage is applied to a nonlinear device or load, the resulting current is not perfectly sinusoidal. In the presence of system impedance this current causes a non-sinusoidal voltage drop and, therefore, produces voltage distortion at the load terminals, i.e. the latter contains harmonics.

To provide an intuitive view of this phenomenon let us consider the circuit of Figure 1.1, where generator G feeds a purely resistive load R_l through a line with impedance $(R_s + jX_s)$ and a static converter.

The generator supplies power (P_{g1}) to the point of common coupling (PCC) of the load with other consumers. Figure 1.1(a) shows that most of this power (P_{l1}) is transferred to the load, while a relatively small part of it (P_{c1}) is converted to power at different frequencies in the static converter. Besides, there is some additional power loss (P_{s1}) at the fundamental frequency in the resistance of the transmission and generation system (R_{s1}).

Figure 1.1(b) illustrates the harmonic power flow. As the internal voltage of the generator has been assumed perfectly sinusoidal, the generator only supplies power at the fundamental frequency and, therefore, the generator's e.m.f. is short-circuited in this diagram, i.e. the a.c. line and generator are represented by their harmonic impedances $(R_{sh} + jX_{sh})$ and $(R_{gh} + jX_{gh})$, respectively. In this diagram the static converter appears as a source of harmonic currents. A small proportion of fundamental power (P_{c1}) is transformed into harmonic power: some of this power ($P_{sh} + P_{gh}$) is consumed in the system (R_{sh}) and generator (R_{gh}) resistances and the rest (P_{lh}) in the load.

Thus the total power loss consists of the fundamental frequency component (P_{s1}) and the harmonic power caused by the presence of the converter ($P_{sh} + P_{gh} + P_{lh}$).

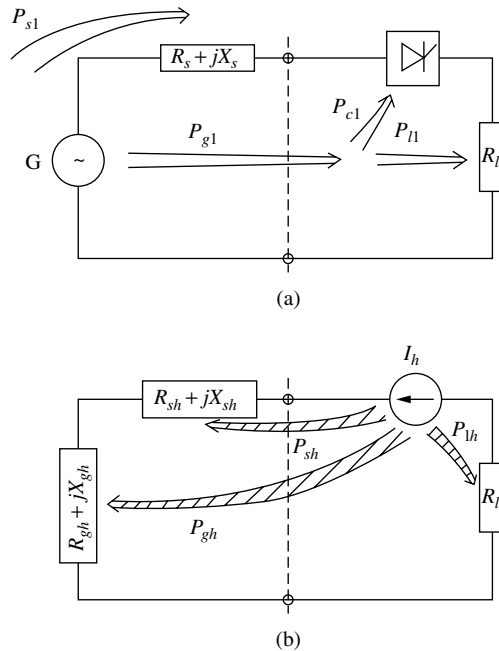

Figure 1.1 (a) Power flow at the fundamental frequency; (b) harmonic power flow

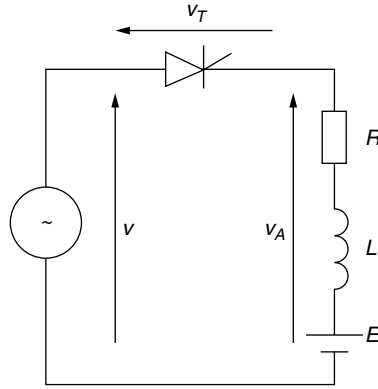

Figure 1.2 Basic circuit to explain the conversion mechanism

For a more rigorous interpretation of the conversion mechanism, let us consider the case of Figure 1.2, where v is a source of sinusoidal voltage and E the constant e.m.f. of a battery with negligible internal resistance.

The thyristor turns ON at $\omega t = \alpha$ and OFF at $\omega t = \beta$ and its voltage drop during conduction is neglected.

Figure 1.3(a), (b) and (c) display respectively the source voltage, the voltage across the thyristor and the load voltage, while Figure 1.3(d) displays the current waveform.

The load voltage V_A can be replaced by the three components shown in Figure 1.4, derived from the Fourier transformation, i.e.

$$V_A = V_{A1} + V_{Ah} + V_{A0} \quad (1.1)$$

where

$$V_{A1} = \sqrt{2}V_{A1} \sin(\omega t + \theta_1) \quad (1.2)$$

is the fundamental component,

$$V_{Ah} = \sum_{h=2}^n \sqrt{2}V_{Ah} \sin(h\omega t + \theta_h) \quad (1.3)$$

is the harmonic content, and

$$V_{A0} = \frac{1}{T} \int_0^T V_A dt = V_{dc} \quad (1.4)$$

is the d.c. component.

Equally, the current can be replaced by the following three components:

$$i_1 = \sqrt{2}I_1 \sin(\omega t + \xi_1) \quad (1.5)$$

$$i_h = \sum_{h=2}^n \sqrt{2}I_h \sin(h\omega t + \xi_h) \quad (1.6)$$

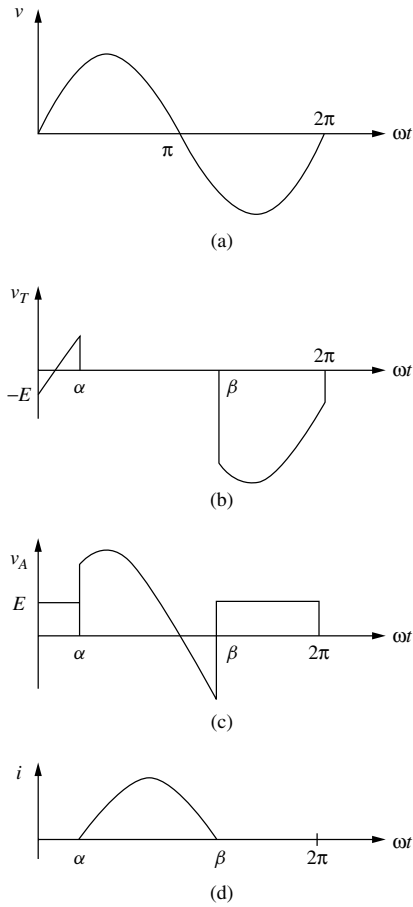

Figure 1.3 Waveforms of the circuit of Figure 1.2: (a) voltage source; (b) voltage across the thyristor; (c) load voltage; (d) current

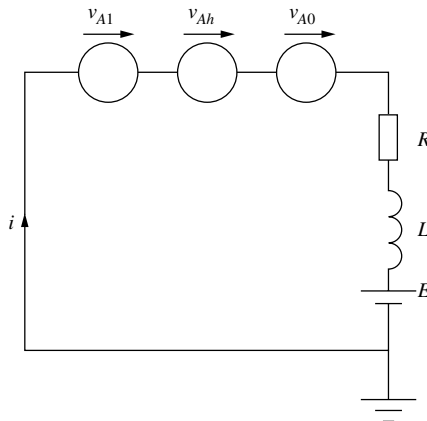

Figure 1.4 Load voltage components of the circuit of Figure 1.2

$$I_0 = \frac{V_{dc} - E}{R} \quad (1.7)$$

Next let us consider the energy aspects.

The active power generated by the source is

$$P_G = V_1 I_1 \cos \xi_1 \quad (1.8)$$

and the power supplied to the load

$$P_A = P_{A1} + P_{Ah} + P_{A0} \quad (1.9)$$

where

$$P_{A1} = V_{A1} I_1 \cos(\theta_1 - \xi_1) = I_1^2 R \quad (1.10)$$

is the power supplied to the fundamental component,

$$P_{Ah} = \sum_{h=2}^n V_{Ah} I_h \cos(\theta_h - \xi_h) = \sum_{h=2}^n I_h^2 R \quad (1.11)$$

is the power supplied to the harmonics, and

$$P_{A0} = V_{dc} I_0 = E I_0 + I_0^2 R \quad (1.12)$$

is the d.c. power.

Therefore the thyristor behaves like an energy converter, i.e. the ideal voltage source combines with the fundamental component of the current waveform to generate the total power P_G .

As the thyristor losses have been ignored $P_G = P_A$ and the following relationship applies:

$$P_G = P_A = I^2 R + E I_0 \quad (1.13)$$

where

$$I = \sqrt{I_0^2 + I_1^2 + \sum_{h=2}^n I_h^2}$$

is the current root mean square (r.m.s.) value

1.3 Definitions and Standards

Power system harmonics are defined as sinusoidal voltage and currents at frequencies that are integer multiples of the main generated (or fundamental) frequency. They constitute the major distorting components of the mains voltage and load current waveforms. However, the increasing content of power system inter-harmonics, i.e.

distorting components at frequencies that are not integer multiples of the fundamental, has prompted a need to give them greater attention.

Most countries have in the past developed their own harmonic standards or recommendations, to suit local conditions. However, with the growth of global trade, the need for equipment manufactured in one country to comply with standards in another has prompted concerted effort in formulating international standards on harmonics and inter-harmonics.

The rationale is to maintain a globally acceptable electromagnetic environment that co-ordinates the setting of emission and immunity limits. This is achieved using reference levels of electromagnetic disturbance, referred to as compatibility levels. The latter are recognised as the levels of severity which can exist in the relevant environment; therefore all equipment intended to operate in that environment is required to have immunity at least at that level of disturbance and, thus, a margin appropriate to the equipment concerned is normally provided between the compatibility and immunity levels.

In determining the appropriate emission limits, the concept of planning level is also used. This is a locally specific level of disturbance adopted as a reference for the setting of emission limits from large installations in order to co-ordinate those limits with the limits adopted for equipment intended to be connected to the power system. Again, the planning level is generally lower than the compatibility level by a specific margin that takes into account the structure and electrical characteristics of the local supply network. This margin is necessary to make allowance for possible system resonance and for an upward drift in the levels on the network due to future loads that may be connected where there is no consent required. Such loads include computers and other home and office electronic equipment that contain switched-mode power supplies. In addition there is uncertainty about the impedance of the supply systems and the customers' equipment at harmonic frequencies.

The relationship between the various levels defined above is illustrated in Figure 1.5.

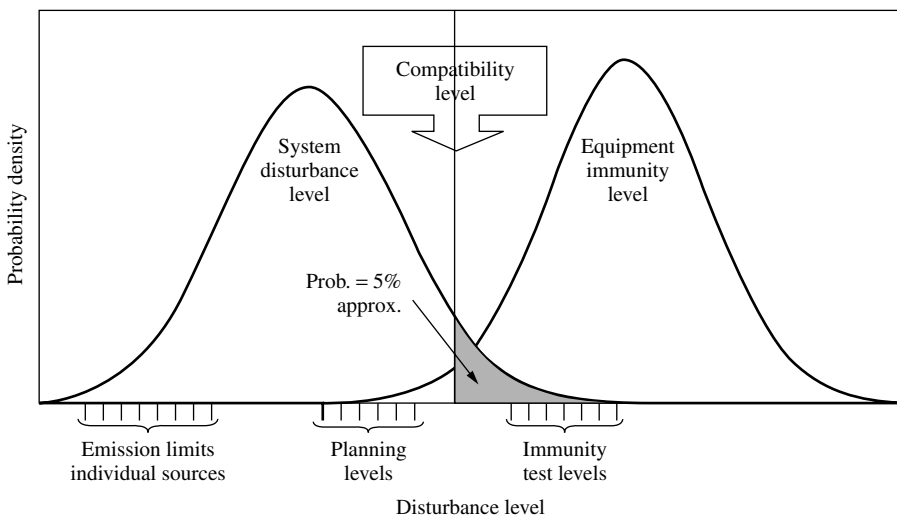

Figure 1.5 Relation between compatibility, immunity, planning and emission levels

1.3.1 Factors Influencing the Development of Standards

The development of harmonic standards is centred around the following issues:

- description and characterisation of the phenomenon;
- major sources of harmonic problems;
- impact on other equipment and on the power system;
- mathematical description of the phenomenon using indices or statistical analysis to provide a quantitative assessment of its significance;
- measurement techniques and guidelines;
- emission limits for different types and classes of equipment;
- immunity or tolerance level of different types of equipment;
- testing methods and procedures for compliance with the limits;
- mitigation guidelines.

The standards themselves may be either system standards, connection standards or, more usually, some combination of the two. In a system standard the emphasis is on the levels of harmonics that can be tolerated in the system, with little or no reference within the body of the standard to the source of harmonics. Details of the harmonic sources, and their likely influence on system harmonic content, are usually given as associated material in appendices.

The limits may be expressed as absolute levels of current or voltage, which may not be exceeded, or as incremental limits allowing small changes to the harmonic source with limited consideration of system effects. The former approach usually permits the connection of certain types and ratings of distorting loads (e.g. converters) to the system without reference to existing harmonic levels. With higher converter ratings the existing harmonic content needs to be established prior to connection, and the proposed additional harmonic source considered in relation to these levels, in order to determine if the limits are likely to be exceeded.

The application of absolute harmonic current limits for individual consumers would seem to provide equal rights for all consumers, large or small. However, this may be considered an unfair distribution by a large consumer connected to a PCC together with a number of small consumers, as it takes no account of their share of the total load. If, instead, the limit is expressed in a way which takes account of the consumer's share of the total load, then this may well be seen as overly restrictive, particularly if a large consumer has little or no disturbing load.

If the limits are expressed in terms of the levels of harmonic voltage at the PCC, then consumers connected to a strong PCC may well benefit relative to a consumer connected to a weak PCC. The adoption of harmonic voltage limits may also mean that, where existing levels are high, new consumers may be forced to install expensive additional circuitry before, connection is permitted. This latter situation constitutes the 'first come, first served' approach.

In considering the type and nature of the limits to be adopted, the different problems presented by the various types of load must be taken into account; the two extremes are groups of small distributed disturbing loads (normally domestic) and large industrial loads. An industrial consumer may also have a number of individual components of

plant, each capable of generating significant harmonic content. Such a consumer is faced with the double problem of ensuring that no harmonic-induced effects occur within its own system, and maintaining the levels at the PCC within the prescribed limits. Experience shows that in many instances where high harmonic levels exist at points within the consumer's own network, these levels do not necessarily penetrate to the external system.

The way in which the harmonics from a number of sources interact on the power system is governed by the random nature of such sources and the variation of their distribution throughout the system, both physically and with time. The random nature of the sources can be accounted for by introducing a diversity factor. This changes the actual ratings of the disturbing loads into an effective rating, which is then used in assessing its relationship with the standard.

1.3.2 Existing Harmonic Standards

The organisation widely recognised as the curator of electric power quality standards is the IEC (International Electrotechnical Commission or Commission Electrotechnique Internationale), based in Geneva. The IEC has defined a series of standards, called Electromagnetic Compatibility (EMC) Standards, to deal with power quality issues. The IEC 61000 series [2] includes harmonics and inter-harmonics as one of the conducted low-frequency electromagnetic phenomena. A widespread alternative to the IEC series is the IEEE 519–1992 document [3], which provides guidelines on harmonics.

There are also standards dealing with specific equipment under the influence of harmonic distortion, such as those of references [4–7], and their relevance will be discussed in Chapter 4.

While the international standards are used as a basis for global co-ordination, individual countries make their own adjustments to accommodate various national priorities. These are normally motivated by the special characteristics of their power system configuration and load management (e.g. the use of ripple control in some countries). Consider as an illustration the power systems of the UK and New Zealand. In the UK a highly interconnected power system with distributed generation serves a large number of load centres, always relatively close to the points of generation. This contrasts with the New Zealand situation, where remote generation centres provide supply to a few, widely separated, major load centres and a large number of scattered small loads. The resulting long transmission lines and comparatively low fault levels increase the vulnerability of the system to harmonic penetration. These factors, taken together with the extensive use made of ripple control, present very different problems than those encountered in the UK to their respective standards committees.

The European Union, through the Electromagnetic Compatibility Directive, has sought to ensure the removal of technical barriers to trade by requiring equipment to operate satisfactorily in its specified electromagnetic environment, and by protecting the public electricity distribution from disturbances emitted by equipment through limiting these emissions. Engineering recommendation ER G5/4 came into force in the UK in March 2001 to ensure that the objectives of the Directive are met for harmonic disturbances. In the revised recommendation planning levels for individual harmonics and for total harmonic distortion (THD) are given for all system voltages from 400 V to 400 kV.

It must also be recognised that no standard relating to system harmonic content can be regarded as permanent, but rather as the current interpretation of system requirements, taking into account the state of monitoring and modelling techniques. As understanding improves through the application of improved measurements and analytical techniques, so must the standards change.

The IEC 61000 Series This section provides a concise description of the documents of the IEC series, which provide internationally accepted information for the control of power system harmonic (and inter-harmonic) distortion. Specific details of their content will be used as needed in the following chapters.

IEC 61000 1-4 Provides the rationale for limiting power frequency conducted harmonic and inter-harmonic current emissions from equipment in the frequency range up to 9 kHz. Relevant background for this document can be found in Chapters 2 and 3.

IEC 61000 2-1 Outlines the major sources of harmonics in three categories of equipment: power system equipment, industrial loads and residential loads.

The increasing use of HVd.c. converters and FACTS devices has become the main source of harmonic distortion originating in the transmission system. Static power converters and electric arc furnaces are the main contributors in the industrial category, and appliances powered by rectifiers with smoothing capacitors (mostly PCs and TV receivers) the main distorting components in the residential category.

IEC 61000 2-2 Contains a section on the compatibility levels of the harmonic and inter-harmonic voltage distortion in public low-voltage power industry systems.

IEC 61000 2-4 Provides harmonic and inter-harmonic compatibility levels for industrial plant. It also describes the main effects of inter-harmonics, a subject discussed in Chapter 3.

IEC 61000 2-12 Similarly to 61000 2-4, this document deals with compatibility levels for low-frequency conducted disturbances, in this case relating to medium voltage power supply systems. It also covers the subject of injected signals such as those used in ripple control.

IEC 61000 3-2 and 3-4 Contain limits for harmonic current emissions by equipment with input currents of 16 A and below per phase. It also specifies the measurement circuit, supply source and testing conditions as well as the requirements for the instrumentation.

IEC 61000 3-6 First, indicates the capability levels for harmonic voltages in low- and medium-voltage networks as well as planning levels for MV, HV and EHV power systems. It then makes an assessment of emission limits for distorting loads in MV and HV power systems.

IEC 61000 3-12 Provides limits for the harmonic currents produced by equipment connected to low-voltage systems with input currents equal to and below 75 A per phase and subject to restricted connection.

IEC 61000 4-7 This is perhaps the most important document of the series, covering the subject of testing and measurement techniques. It is a general guide on harmonic and inter-harmonic measurements and instrumentation for power systems and equipment connected thereto. The application of this document is discussed in Chapter 5.

IEC 61000 4-13 This is also a document on testing and measurement techniques with reference to harmonics and inter-harmonics, including mains signalling at a.c. power ports as well as low-frequency immunity tests.

IEEE 519-1992 [3] Document IEEE 519-1992 identifies the major sources of harmonics in power systems. The harmonic sources described in this standard include power converters, arc furnaces, static VAR compensators, inverters of dispersed generation, electronic phase control of power, cycloconverters, switch mode power supplies and pulse-width modulated (PWM) drives. The document illustrates the typical distorted wave shapes, the harmonic order numbers and the level of each harmonic component in the distortion caused by these devices. It also describes how the system may respond to the presence of harmonics. The discussion on responses comprise parallel resonance, series resonance and the effect of system loading on the magnitude of these resonances. Based on typical characteristics of low-voltage distribution systems, industrial systems and transmission systems, this document discusses the general response of these systems to harmonic distortion.

The effects of harmonic distortion on the operation of various devices or loads are also included in the standard. These devices comprise motors and generators, transformers, power cables, capacitors, electronic equipment, metering equipment, switchgear, relays and static power converters. Interference to the telephone networks as a result of harmonic distortion in the power systems is discussed with reference to the C-message weighting system created jointly by Bell Telephone Systems and Edison Electric Institute (described in Chapter 4). The standard outlines several possible methods of reducing the amount of telephone interference caused by harmonic distortion in the power system.

This standard also describes the analysis methods and measurement requirements for assessing the levels of harmonic distortion in the power system. It summarises the methods for the calculation of harmonic currents, system frequency responses and modelling of various power system components for the analysis of harmonic propagation. The section on measurements highlights their importance and lists various harmonic monitors that are currently available. It describes the accuracy and selectivity (the ability to distinguish one harmonic component from others) requirements on these monitors; it also describes the averaging or snap-shot techniques that can be used to 'smooth-out' the rapidly fluctuating harmonic components and thus reduce the overall data bandwidth and storage requirements.

The standard describes methods for designing reactive compensation for systems with harmonic distortion. Various types of reactive compensation schemes are discussed, indicating that some of the equipment, such as TCR and TSC, are themselves

sources of harmonic distortion. It also outlines the various techniques for reducing the amount of harmonic current penetrating into the a.c. systems. Recommended practices are suggested to both individual consumers and utilities for controlling the harmonic distortion to tolerable levels. This standard concludes with recommendations for evaluating new harmonic sources by measurements and detailed modelling and simulation studies. It provides several examples to illustrate how these recommendations can be implemented effectively in practical systems.

Notching, the distortion caused on the line voltage waveform by the commutation process between valves in some power electronic devices, is described in detail. The document analyses the converter commutation phenomenon and describes the notch depth and duration with respect to the system impedance and load current. Limits are outlined in terms of the notch depth, THD of supply voltage and notch area for different supply systems.

1.3.3 General Harmonic Indices

The most common harmonic index, which relates to the voltage waveform, is the THD, which is defined as the root mean square (r.m.s.) of the harmonics expressed as a percentage of the fundamental component, i.e.

$$\text{THD} = \frac{\sqrt{\sum_{n=2}^N V_n^2}}{V_1}$$

where V_n is the single frequency r.m.s. voltage at harmonic n , N is the maximum harmonic order to be considered and V_1 is the fundamental line to neutral r.m.s. voltage.

For most applications, it is sufficient to consider the harmonic range from the 2nd to the 25th, but most standards specify up to the 50th.

Current distortion levels can also be characterised by a THD value but it can be misleading when the fundamental load current is low. A high THD value for input current may not be of significant concern if the load is light, since the magnitude of the harmonic current is low, even though its relative distortion to the fundamental frequency is high. To avoid such ambiguity a total demand distortion (TDD) factor is used instead, defined as:

$$\text{TDD} = \frac{\sqrt{\sum_{n=2}^N I_n^2}}{I_R}$$

This factor is similar to THD except that the distortion is expressed as a percentage of some rated or maximum load current magnitude, rather than as a percentage of the fundamental current. Since electrical power supply systems are designed to withstand the rated or maximum load current, the impact of current distortion on the system will be more realistic if the assessment is based on the designed values, rather than on a reference that fluctuates with the load levels.

Consider as an example the case of a three-phase purely resistive load of 50 kW rating supplied directly from a 50 Hz three-phase 415 V (phase-to-phase) bus. At the time of measuring, the load was consuming 41.5 kW and the voltage waveform contained 11 V of negative-sequence fifth harmonic and 8 V of positive-sequence seventh harmonic. Assuming that the load resistance varies with the square root of the harmonic order h , the following steps are used to calculate the THD and TDD indices at the point of connection:

Load resistance values:

$$R_1 = \frac{V_1^2}{P_1} = \frac{(415/\sqrt{3})^2}{(41\,500/3)} = 4.15 \, \Omega$$

$$R_5 = R_1\sqrt{h} = 4.15\sqrt{5}$$

$$R_7 = R_1\sqrt{h} = 4.15\sqrt{7}$$

Load current components:

$$I_r = \frac{50}{415\sqrt{3}} = 69.56 \, \text{A}$$

$$I_1 = \frac{(V_1/\sqrt{3})}{R_1} = \frac{(415/\sqrt{3})}{4.15} = 57.735 \, \text{A}$$

$$I_5 = \frac{(V_5/\sqrt{3})}{R_5} = \frac{(11/\sqrt{3})}{(4.15\sqrt{5})} = 0.6844 \, \text{A}$$

$$I_7 = \frac{(V_7/\sqrt{3})}{R_7} = \frac{(8/\sqrt{3})}{(4.15\sqrt{7})} = 0.4207 \, \text{A}$$

$$\text{THD}_v = \frac{\sqrt{(V_5^2 + V_7^2)}}{V_1} = \frac{\sqrt{(11^2 + 8^2)}}{415} = 0.03276$$

$$\text{THD}_i = \frac{\sqrt{(I_5^2 + I_7^2)}}{I_1} = \frac{\sqrt{(0.68438)^2 + (0.42066)^2}}{57.735} = 0.01391$$

$$\text{TDD}_i = \frac{\sqrt{(I_5^2 + I_7^2)}}{I_r} = \frac{\sqrt{(0.68438)^2 + (0.42066)^2}}{69.56} = 0.01155$$

An important question left out of present standards is how to apply the indices to three-phase systems. It is, of course, possible to calculate the indices in each phase individually and apply the limits to the highest. Alternatively, some type of averaging could be carried out. This matter is discussed further in Chapter 4 with reference to telephone interference.

1.4 Relevance of the Topic

Perhaps the most noticeable consequence of power system harmonics is the degradation of telephone communications caused by induced harmonic noise. There are,

however, more disastrous effects, such as the maloperation of important control and protection equipment and the overloading of power plant. Very often the presence of harmonics is only detected following an expensive casualty (like the destruction of power factor correction capacitors). Normally these components have to be replaced, and the equipment protected by filters, at the customer's expense.

In recent times there have been considerable developments in industrial processes that rely on controlled rectification for their operation, and therefore generate harmonic currents. The design of such equipment often assumes the existence of a symmetrical voltage source free of harmonic distortion, a situation that only occurs in the absence of other harmonic sources or when the supply system is very strong (i.e. of negligible impedance). Consequently, the smaller industrial users of electricity are being subjected to increasing operating difficulties as a result of the harmonic interaction of their own control equipment with the power supply.

With open electricity markets, the number of players will increase considerably. The competitive electricity trade should not degrade the level of security, for which the requirements of clients are likely to be more stringent. A general power quality standard, although difficult to define, must be guaranteed by the system operator. However, power quality can raise complicated problems that require detailed information and technical skills to find adequate solutions.

Although interruptions and voltage dips can, to a certain extent, be mastered by the system operator, harmonic voltage fluctuations cannot, since they are generally customers' emissions. It is not clear, then, who should take the risk of ensuring specified levels of harmonic distortion. The obvious thing to do is to put standards on emission limits, but the question is to decide who will control the users' voltage disturbance emissions and who will charge them for this. An innovative approach is for the distribution companies to be responsible for supplying electricity to any user with defined disturbances levels, with a system of penalisation or compensation if these levels are exceeded.

Utilities are likely to accept different levels of compromise between security and cost, and the consequence of this difference is that the party with stricter standards might be left to solve its neighbours' 'problems'. In practice, the party with relaxed standards will rely on others for the provision of support services. If it is not possible to harmonise the power quality standards between the interconnected utilities, proper commercial arrangements will be needed to reflect the consequences of these differences. While it may seem obvious that hardware and software systems should be installed to monitor performance and delivery of agreed service provision, in reality these are not always available.

Power quality awareness in general, and waveform distortion in particular, is likely to increase with deregulation as the competitive environment will try to drive to the limit the use of existing facilities and networks with as little expenditure as possible. The risk of harmonic resonances and their effect on shunt capacitor destruction is well documented. However, some of the negative consequences of this approach may not be immediately obvious, particularly the effect of harmonics on equipment overloading. For instance, the life of a transformer will be considerably reduced by the extra current loading imposed by harmonics. Thus there is a need to adapt existing recommendations, put in place appropriate commercial arrangements and, most of all, monitor their implementation more rigorously than in the past.

In pre-deregulation days, the allocation of responsibilities to maintain adequate standards, largely determined by the supply companies, given the inadequate simulation and monitoring tools available, could not be technically challenged effectively. Deregulation will encourage the use of advanced simulation and assessment tools for the customer to make informed decisions when dealing with the power supply companies.

The competitive electricity market has made utilities more conscious of the need to satisfy their customers' needs and not simply to supply them with electricity. For instance, Electricité de France conducts surveys to analyse customers' expectations.

The new environment provides a considerable challenge that will force the utilities to ensure that individual customer's needs are met. This implies developing complementary services taking into account the customer's specific requirements.

The lack of enforceable harmonic standards in the past did not encourage the use of expensive monitoring, testing and software tools. The development of such tools has accelerated with the acceptance of more stringent standards. Deregulation is leading to more transparent considerations of power quality issues and to a more contestable environment, where the independent parties can be adequately represented. In this environment, information about harmonics itself has become a valuable commodity, giving rise to profitable consulting services. This presents an important problem for the system operators, that of maintaining power quality when the parties are reluctant to provide all the necessary information.

In the competitive environment, waveform distortion can be jeopardised by excessive confidentiality. To allow the interconnected network to maintain adequate harmonic levels at low cost, this must be given priority over confidentiality. To ensure this policy, it is essential that the system operator obtains information and makes it generally available to all market participants. Determining limits on harmonic levels is a difficult exercise. Current knowledge is still insufficient to ascertain the extent to which any given power system can sustain a particular level of harmonics and remain viable in terms of the functions that the system has to perform. Two major impediments to such understanding are the ability to make accurate measurements (discussed in Chapter 5) and the state of computer simulation (discussed in Chapters 7 and 8).

It is relatively easy, though expensive, to keep the harmonic contribution of large nonlinear plant components such as HVd.c. converters under control, normally by the connection of passive filters. The situation is less straightforward in power distribution systems, where the exact location and/or operating characteristics of the dispersed loads are not well defined. Moreover, the harmonic distortion levels of distribution systems appear to be increasing at a consistent rate. A report [8] on extensive field tests carried out in several New England Power Service Co. distribution feeders indicated an increase in THD of the order of 0.1% per year, with the fifth harmonic causing the greatest concern. There is a need for more global planning for the limitation of harmonic distortion in distribution systems.

Concern for waveform distortion must be shared by all the parties involved in order to establish the right balance between exercising control by distortion and keeping distortion under control. Early co-ordination between the interested parties is essential to achieve acceptable economic solutions.

1.5 References

1. Fourier, J.B.J. (1822) *Théorie Analytique de la Chaleur*, Paris.
2. IEC 61000-2-1 (1990) Electromagnetic Compatibility (EMC)—Part 2: Environment—Section 1: Description of the Environment—Electromagnetic Environment for Low-Frequency Conducted Disturbances and Signalling in Public Power Supply Systems. IEC, Geneva.
3. IEEE 519-1992, IEEE Recommended Practices and Requirements for Harmonic Control in Electrical Power Systems (ANSI). IEEE, New York.
4. CCITT (1963) Directives Concerning the Protection of Telecommunication Lines against Harmful Effects from Electricity Lines, International Telecommunications Union, Geneva.
5. Engineering Reports of the Joint Subcommittee on Development and Research of the Edison Electric Institute and the Bell telephone System, New York, 5 volumes, July 1926 to January 1943.
6. IEEE/ANSI C57.110-1998, IEEE Recommended Practice for Establishing Transformer Capability when Supplying Nonsinusoidal Load Currents. IEEE, New York.
7. IEEE/ANSI Std 18-2002 (Reaff 1991), IEEE Standard for Shunt Power Capacitors. IEEE, New York.
8. Nejdawi, I.M., Emmanuel, A.E., Pileggi, D.J., Corridori, M.J. and Archambeault, R.D. (1999) Harmonic trends in NE USA: a preliminary view, *Trans. IEEE Power Delivery*, **14**(4), 1488–1494.

