

Bernhard Maidl, Leonhard Schmid,
Willy Ritz, Martin Herrenknecht

Hardrock Tunnel Boring Machines

In co-operation with
Gerhard Wehrmeyer and Marcus Derbort

B. Maidl, L. Schmid, W. Ritz,
M. Herrenknecht

Hardrock Tunnel Boring Machines

Bernhard Maidl, Leonhard Schmid,
Willy Ritz, Martin Herrenknecht

Hardrock Tunnel Boring Machines

In co-operation with
Gerhard Wehrmeyer and Marcus Derbort

o. Prof. Dr.-Ing. Dr. h. c. mult. Bernhard Maidl
Ruhr-Universität Bochum
Fakultät Bauingenieurwesen
Lehrstuhl für Bauverfahrenstechnik, Tunnelbau
und Baubetrieb
44780 Bochum

Cover picture: Gripper TBM for the Gotthard Base Tunnel, Switzerland

Bibliographic information published by the Deutsche Nationalbibliothek
Die Deutsche Nationalbibliothek lists this publication in the Deutsche Nationalbibliografie;
detailed bibliographic data are available in the Internet at <<http://dnb.ddb.de>>.

ISBN 978-3-433-01676-3

© 2008 Ernst & Sohn Verlag für Architektur und technische Wissenschaften GmbH und Co.KG, Berlin

All rights reserved, especially those of translation into other languages. No part of this book shall be reproduced in any form - i.e. by photocopying, microphotography, or any other process - or be rendered or translated into a language useable by machines, especially data processing machines, without the written permission of the publisher.

Registered names, trademarks, etc. used in this book, even when not specifically marked as such, are not to be considered unprotected by law.

Typesetting: ProSatz Unger, Weinheim
Printing: Strauss GmbH, Mörlenbach
Binding: Litges & Dopf GmbH, Heppenheim
Printed in Germany

Preface

“... I have discovered methods for tunnels and engulfed secret ways, which are excavated without any noise, in order to reach predetermined locations, even if they have to be dug under ditches or under a river.”

“... I have noiseless methods to dig tunnels and winding secret catacombs in order to reach a pre-planned place, even if they have to be built underneath ditches and rivers.”

(Leonardo da Vinci, 1452–1519)

Leonardo da Vinci is considered to be one of the greatest inventors of all times. His revolutionary and futuristic construction plans e.g. in aviation and in the construction of canals and bridges were ridiculed during his time. Many of his discoveries were later ‘re-invented’ at times when they were actually necessary.

A horizontal drilling machine cannot be found among Leonardo’s known and published sketches, but he elaborated extensively about their usage and advantages in the construction of shafts. In his writings one can find descriptions of the method of drilling horizontal or vertical shafts, which means that he had already plans for useful applications in this field before Agricola, Brunel and all the following patent holders.

The drilling of tunnels has a long history. First patents were already distributed in the beginning of the 19th Century, but it took almost another century until a similar machine had drilled a longer distance through mountains. There were several reasons for this delay. Among them were ineffective mining tools, which were too soft, but above all it was the lack of sufficient energy sources at the workplace. In those days movable steam engines, even hydraulic devices for blasting rock formations were in use, but those techniques were not effective enough to dig a tunnel through an entire mountain.

Nowadays TBM tunnelling gains more and more significance in hard rock formations even with larger diameters. The number of substantially longer tunnels as well in road and rail traffic, as in the areas of supply and waste are constantly on the rise; not only are those projects worth mentioning like the Alpine tunnels that are in process or in developmental stages, but also those subterranean tunnels underneath straits, which will be realized in the future. Those procedures are still considered as spectacular. Bernard Kellermann wrote about a similar project in his utopian best seller ‘The Tunnel’ (published in 1921), describing the construction of a railway tunnel connecting Europe with the North American continent by means of four drills.

The varying usage of open tunnel drills with grippers will be extended from that for smaller or medium diameters to larger, which will be effective also under mixed geological circumstances. Those mixed geological circumstances have already led to an enormous push in the development of the shield machines and prefabricated tunnel linings. Open hard rock machinery has no or only a short protective shield and as a result, its usage is rather limited under difficult geological circumstances. Currently there is a

development of open hard rock machinery on the way, with the main focus on securing the area behind the drill head and advanced safety. The safety systems, with shotcrete, anchors and plates, which were developed for the traditional construction of tunnels are not of much use for continuous boring with Gripper-TBMs. Still, one cannot foresee if there are modifications of existing procedures possible or if one has to find completely new ways of dealing with these problems. In addition there is further demand for refining the use of tunnel bore machines in high altitude with high pressure.

The goal of the authors, Maidl, Schmid, Ritz and Herrenknecht was to accumulate existing knowledge and experience, to define requirements of use and to present as well as to encourage potential developments. This endeavour requires an interaction of Science and Practice at the highest level.

I am grateful to the entire team of collaborators, primarily, Leonhard Schmid, without whose contribution this book would have never been written, as well as, Martin Herrenknecht and Willy Ritz for their work on specific chapters of this book. Hereby I also acknowledge the support of the associates of my co-authors and the companies for providing the most current information. Furthermore I like to express my gratitude to Gerhard Wehrmeyer and Marcus Derbort for their coordination and detailed analyses, as well as the collaborators from the chair, who were involved in the writing of additional articles, Ahmed Karroum and Volker Stein. Also many thanks to the staff members from the engineering office of Maidl/Maidl, Ulrich Maidl and Matteo Ortu and my technical assistant, Helmut Schmid for his expert draftsman ship, Christian Drescher for his typing and my secretaries, Brigitte Wagner and Ruth Wucherpfennig, for their varied assistance and also to Gerhard Wehrmeyer.

February 2008

Bernhard Maidl

Contents

1	Historical Development and Future Challenges	1
2	Basic Principles and Definitions	15
2.1	Basic Principles and Construction	16
2.1.1	Boring System	16
2.1.2	Thrust and Clamping System	17
2.1.3	Muck Removal System	18
2.1.4	Support System	18
2.2	Definitions and Terms	20
2.2.1	Tunnel Boring Machines with Full-Face Excavation	20
2.2.1.1	Gripper TBM	20
2.2.1.2	Shielded TBM	22
2.2.2	Tunnel Boring Machines for Partial Excavation	23
3	Boring Operation	25
3.1	The Boring Process	25
3.2	The Cutter Head	26
3.2.1	Shape of the Cutter Head	27
3.2.2	Clearing the Muck in the Excavation Area	29
3.2.3	Cutter Head Construction and Soil Consolidation	31
3.3	Cutting Tools	32
3.3.1	General	32
3.3.2	Working Method of Cutter Discs	33
3.3.3	Cutter Spacing	36
3.3.4	Penetration	38
3.3.5	Wear	41
3.3.6	Wear and Water	48
3.3.7	Cutter Housing	49
3.4	The Main Drive	50
3.4.1	Types of Main Drive	50
3.4.2	Main Bearing	53
3.5	Advance Rate	53
3.6	Special Types	55
3.6.1	Reamer TBMs	56
3.6.2	Bouygues System	57
3.6.3	Mobile Miner (Robbins)	58
3.6.4	Back-Cutting Technology	58
3.6.4.1	Mini-Fullfacer (Atlas Copco)	58
3.6.4.2	Continuous Miner	60
3.6.5	Shaft Sinking	61
3.6.5.1	Raise Boring	62

3.6.5.2	Blind Drilling	64
3.6.5.3	Combinations	65
4	Thrust	67
4.1	General	67
4.2	Advance with Gripper Clamping	67
4.3	Advance with a Shield TBM	72
5	Material Transport	75
5.1	Material Transport at the Machine	75
5.2	Material Transport Through the Tunnel	77
5.2.1	Rail Transport	77
5.2.1.1	Diesel or Electric Operation	79
5.2.1.2	Muck Cars	79
5.2.1.3	Loading in the Tunnel	80
5.2.1.4	Train Timetable	80
5.2.1.5	Tunnel Track	81
5.2.2	Trackless Operation	81
5.2.2.1	Transport Vehicles	82
5.2.2.2	Haul Road	82
5.2.2.3	Loading	82
5.2.3	Conveyor Transport	84
5.2.3.1	Conveyor Storage	85
5.2.3.2	Conveyor Belt Extension and Belt Operation	85
5.2.3.3	Advantages of Conveyor Transport and Innovation Potential	87
6	Backup Equipment	89
6.1	Backup Concept	89
6.2	Design Specifications	93
7	Ventilation, Dust Removal, Working Safety, Vibration	99
7.1	Ventilation	99
7.1.1	Danger	99
7.1.2	Ventilation Schemes, Ventilation Systems	99
7.2	Dust Removal	100
7.3	Occupational Safety and Safety Planning for TBM Operation	103
7.3.1	General	103
7.3.2	International Guidelines and National Regulations	104
7.3.2.1	International Guidelines	104
7.3.2.2	National Regulations	104
7.3.3	Integrated Safety Plan	106
7.3.3.1	The Safety Plan in the Environment of Management Plans	106
7.3.3.2	Safety Aims	107
7.3.3.3	Description of Dangers and Risk Analyses	107

Contents	IX
7.3.3.4	Action Plan 109
7.3.4	TBM Details and Specifics Regarding Natural Gas Danger and Rock Support 110
7.3.4.1	Natural Gas Danger 110
7.3.4.2	Rock Support 111
7.4	Vibration 111
8	Additional Equipment 115
8.1	Investigation and Improvement of the Geological Conditions 115
8.2	Equipment for Rock Support 117
8.2.1	Anchor Drills 117
8.2.2	Steel Ring Equipment 118
8.2.3	Mesh Installation Equipment 118
8.2.4	Innovation Aims 119
8.3	TBM Steering 119
8.3.1	Steering the Gripper TBM with Single Bracing 119
8.3.2	Steering the Gripper TBM with X-Type Clamping 122
8.3.3	Steering a Single Shield TBM 122
8.3.4	Steering a Double Shield TBM 125
8.4	Surveying 126
8.4.1	Surveying the Position of the Tunnel Boring Machine 127
8.4.2	Forward Calculation of the TBM Route 127
9	Tunnel Support 129
9.1	General 129
9.2	Support Systems and Advance Rates 130
9.3	Systematic Support at the Machine 133
9.3.1	Steel Arch Support 133
9.3.2	Liner Plates 136
9.3.3	Segments 137
9.3.3.1	Invert Segments 137
9.3.3.2	Segmental Lining 137
9.4	Shotcrete Support 142
9.4.1	Shotcrete Support at the Machine 142
9.4.2	Shotcrete Support in the Backup Area 143
9.5	Localised Support 144
9.5.1	Anchors and Mesh 144
9.5.2	Arch Support 145
9.6	Stabilisation Ahead of the Cutter Head 146
10	Gripper TBM and Shield Machine Combinations 149
10.1	Roof Shields 149
10.2	Roof Shield and Side Steering Shoes and Cutter Head Shields 152
10.3	Walking Blade Gripper TBM 153

10.4	Full-Face Shield Machines	155
10.4.1	Developments	155
10.4.2	Special Characteristics	156
10.4.2.1	Cutter Head and Shield	157
10.4.2.2	Thrust Ring	157
10.5	Double Shields	159
10.5.1	Developments	159
10.5.2	Functional Principle	159
10.5.3	Special Cases	160
10.5.3.1	Shield and Bentonite Lubrication	160
10.5.3.2	Telescopic Shield	161
10.6	Slurry Shield Machines	163
10.6.1	Developments	163
10.6.2	Working Principle	163
10.7	Shields with Screw Conveyors	165
10.7.1	Developments	165
10.7.2	Working Principle	165
10.7.3	Machine Types	167
10.7.3.1	Open Mode (Screw Conveyor – Conveyor Belt)	167
10.7.3.2	Closed Mode (Screw Conveyor – Conveyor Belt)	167
10.7.3.3	Closed Mode (Slurry Circuit)	168
10.7.3.4	EPB Mode (Screw Conveyor – Conveyor Belt or Screw Conveyor/Slurry Pump)	169
10.7.3.5	Open Mode (Conveyor Belt)	170
10.8	Micro Machines for Hard Rock	172
10.8.1	Mini TBM	172
10.8.2	Pipe Jacking	174
10.8.2.1	Press-Boring Pipe Jacking	174
10.8.2.2	Shield Pipe Jacking	174
11	Special Processes: Combinations of TBM Drives with Shotcrete	177
11.1	Scope of Application	177
11.2	Construction Options	178
11.2.1	Probe Headings	178
11.2.2	Pilot Headings	180
11.2.3	Enlargement for Stations, Points or Machine Halls	181
11.3	Examples	183
11.3.1	Piora-Mulde Probe Heading	183
11.3.2	Kandertal Probe Heading	184
11.3.3	Uznaberg Pilot Heading	188
11.3.4	Enlargement at the Connecting Structure at Nidelbad Zürich–Thalwil Tunnel	190

12	Geological Investigations and Influences	195
12.1	General	195
12.2	Influences on the Boring Process	199
12.3	Influences on the Machine Clamping	202
12.4	Influences on the Rock Support	205
13	Classification for Excavation and Support	207
13.1	General and Objectives for Mechanised Tunnelling	207
13.2	Classification Systems	208
3.2.1	Classification According to Rock Properties	208
13.2.1.1	RMR System (Rock Mass Rating System)	208
13.2.1.2	Q System (Quality System)	211
13.2.2	Classification According to Cuttability and Abrasiveness	220
13.2.3	Classification According to Type, Extent and Location of the Support Work Required	222
13.3	Standards, Guidelines and Recommendations for the Classification of Mechanised Tunnelling	223
13.3.1	Classification in Germany	223
13.3.2	Classification in Austria	228
13.3.3	Classification in Switzerland	234
13.4	Classification Suggestion by the Authors	239
14	Tendering, Award, Contract	243
14.1	Procedure Examples	243
14.1.1	Procedure in Switzerland	243
14.1.1.1	General	243
14.1.1.2	Tender Evaluation	244
14.1.1.3	Quality Management	245
14.1.1.4	Assignment of Risks in the Contract	246
14.1.1.5	Geologically or Geotechnically Altered Conditions, Altered Orders, Altered Schedules	249
4.1.2	Procedure in the Netherlands	249
14.1.2.1	Tendering and Negotiation Procedure with the Botlek Tunnel as an Example	249
14.1.3	Procedure in Germany	252
14.2	Design and Geotechnical Requirements in the Tendering of a Mechanised Tunnelling as Alternative Proposal	253
14.2.1	Introduction	253
14.2.2	Examples	253
14.2.2.1	Adler Tunnel	253
14.2.2.2	Sieberg Tunnel	254
14.2.2.3	Stuttgart Airport Tunnel	255
14.2.2.4	Rennsteig Tunnel	257
14.2.2.5	Lainz Tunnel	258

14.2.3	Additional Requirements for Mechanised Tunnelling Concept in the Tender Documents	260
14.2.3.1	Geology and Hydrology	261
14.2.3.2	Design and Construction Process	261
14.2.3.3	Specification and Contract	262
14.2.4	Decisions Based on Cost	262
14.2.4.1	Design Phase and Preparation for Tendering	262
14.2.4.2	Tendering Phase	263
14.2.4.3	Construction Phase and Final Payment	263
14.2.5	Forecast	263
15	Tunnel Lining	265
15.1	General	265
15.2	Design Principles for Tunnel Linings	265
15.2.1	Single-Shell and Double-Shell Construction	265
15.2.2	Watertight and Water-Draining Forms of Construction	267
15.3	Lining with Concrete Segments	269
15.3.1	General	269
15.3.2	Construction Types	271
15.3.2.1	Block Segments with Right-Angled Plan	271
15.3.2.2	Hexagonal or Honeycomb Segments	274
15.3.2.3	Rhomboidal and Trapezoidal Segment Systems	275
15.3.2.4	Expanding Segments	276
15.3.2.5	Yielding Lining Systems	277
15.3.3	Joint Detailing	282
15.3.3.1	Longitudinal Joints	282
15.3.3.2	Ring Joints	286
15.3.4	Steel Fibre Concrete Segments	289
15.3.5	Grouting Annular Gap	290
15.3.5.1	Filling with Gravel	290
15.3.5.2	Mortar Grouting	291
15.3.6	Measures for Waterproofing Tunnels with Segment Linings	291
15.3.6.1	Sealing Bands	292
15.3.6.2	Injecting	294
15.3.7	Segment Production	295
15.3.8	Damages	296
15.3.8.1	Damage During Ring Erection	297
15.3.8.2	Damage During Excavation	297
15.3.8.3	Damage at the Shield Tail Seal	298
15.3.8.4	Damage after Leaving the Shield	298
15.3.8.5	Repair of Damage	299
15.4	Cast in-situ Linings	299
15.4.1	General	299
15.4.2	Construction	300

Contents	XIII
15.4.3	Manufacture 300
15.5	Shotcrete Layers as the Final Lining 301
15.6	Structural Investigations 302
16	Examples of Completed Tunnels 303
16.1	Tunnel Excavation with Gripper TBMs 303
16.1.1	Control and Drainage Tunnel, Ennepe Reservoir 303
16.1.2	Manapouri Underwater Tunnel, New Zealand 305
16.2	Tunnelling with Shield TBMs 313
16.2.1	San Pellegrino Tunnel, Italy 313
16.2.2	Zürich–Thalwil Twin-Track Tunnel, Section Brunau–Thalwil 317
16.3	Inclined Shaft Tunnelling with Double Shield 321
16.3.1	Cleuson–Dixence Pressure Shaft 321
References 327
Index 337

1 Historical Development and Future Challenges

Tunnelling developed rapidly during the industrialisation at the start of the 19th century with the building of the railway network. In hard rock, this was by drilling and blasting. The first stage of the developing mechanisation of tunnelling therefore was the development of efficient drills for drilling holes for the explosive [96]. There were also attempts to excavate the rock completely by machine.

The story of the development of the first tunnel boring machines contains, besides the technically successful driving of the Channel Tunnel exploratory tunnels by Beaumont machines, many attempts, which failed due to various problems. Either the technological limits of the available materials were not observed or the rock to be tunnelled was not suitable for a TBM. The early applications were successful where the rock offered the ideal conditions for a TBM.

The first tunnelling machines were not actually TBMs in the true sense. They did not work the entire face with their excavation tools. Rather the intention was to break out a groove around the wall of the tunnel. After this had been cut, the machine was withdrawn and the remaining core loosened with explosives or wedges. This was the basic principle of the machine designed and built in 1846 by the Belgian engineer Henri-Joseph Maus for the Mount Cenis tunnel (Fig. 1-1). The machine worked with hammer drills chiselling deep annular grooves in the stone, dividing the face into four 2.0×0.5 m high stone blocks. Although this machine demonstrated its performance capability for two years in a test tunnel, it was not used for the construction of the Mount Cenis tunnel because of doubts about the drive equipment. The compressed air to power the drills was to be provided by water powered compressors at the portal and fed to the machine through pipes. Considering the 12,290 m length of the tunnel, Maus expected that only about 22 kW of the 75 kW generated would arrive at the machine. It also turned out that the material used at that time could not resist the wear during tunnelling. The result would have been increased wear of the bits. Despite these problems, Maus assumed an average advance rate of 7 m, or considering downtime for cutter change, 5 m per day.

The American Charles Wilson developed and built a tunnel boring machine as early as 1851, which he first patented in 1856 (Fig. 1-2). The machine had all the characteristics of a modern TBM and can thus be classified as the first machine, which worked by boring the tunnel. The entire face was excavated using disc cutters, which Wilson had already developed in 1847 and applied for a patent for. The tools were arranged on a rotating cutter head and the thrust required for cutting was resisted by pressure sideways against the rock. In comparison with modern TBMs, the integration of a rotating mounting for the disc cutters stands out. The mounting plate was arranged with its rotational axis perpendicular to the tunnel centreline in the cutter head holder, which combined with the rotation of the outer cutting head to cut a hemispherical face. Wilson's machine underwent various tests in 1853. After advancing about 3 m in the Hoosac tun-

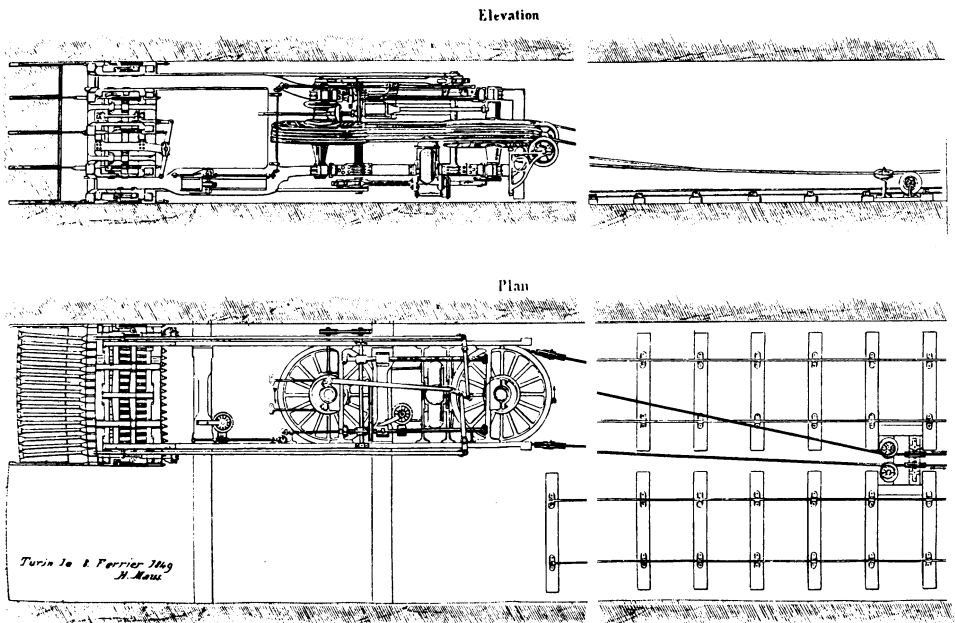

Figure 1-1
Tunnelling machine by H.-J. Maus, Mount Cenis tunnel, 1846 [159]

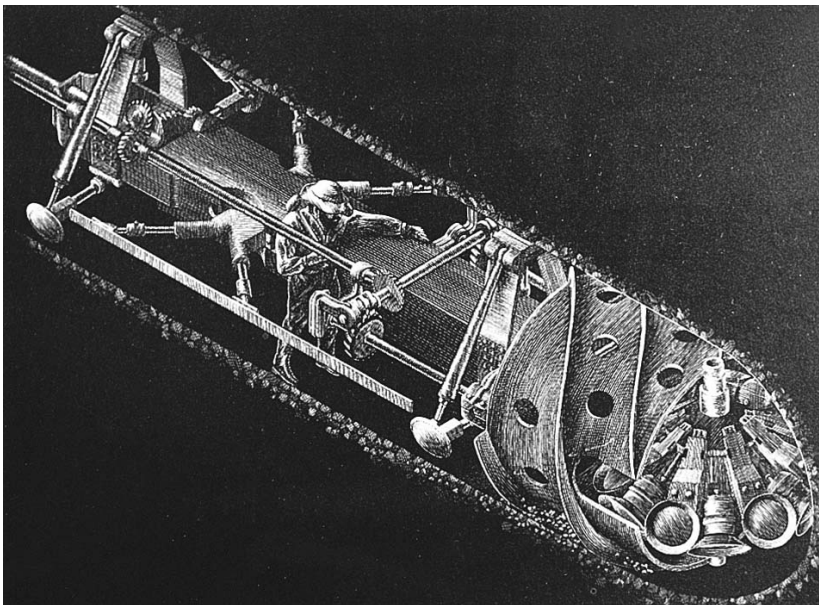

Figure 1-2
First tunnel boring machine by C. Wilson, Hoosac tunnel, 1853 [127]

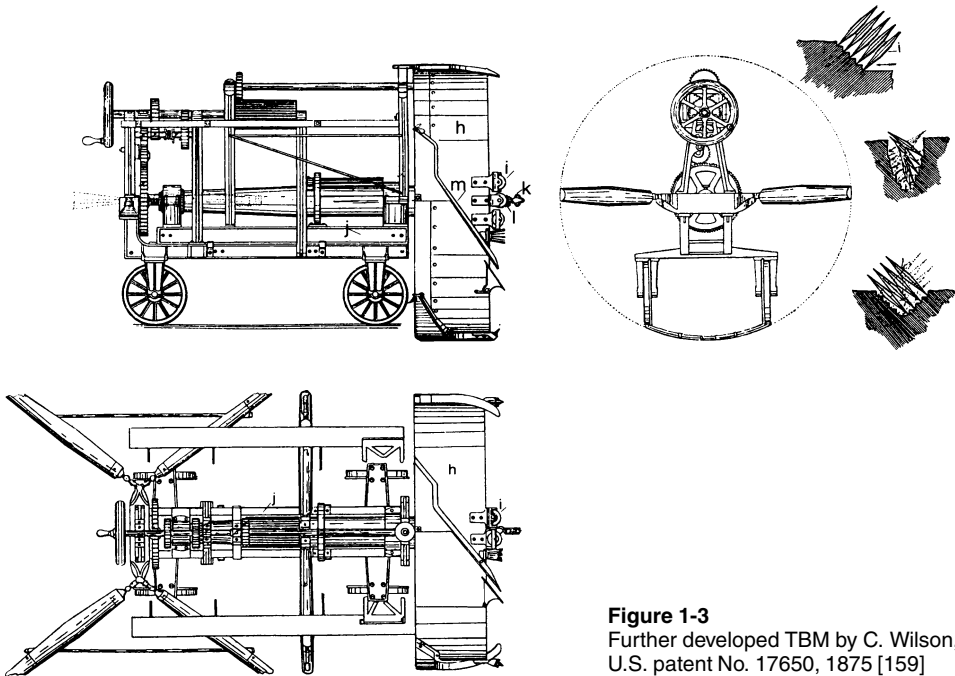

Figure 1-3
Further developed TBM by C. Wilson,
U.S. patent No. 17650, 1875 [159]

nel (Boston, USA), the machine proved, because of problems with the disc cutters, unable to compete with the established drill and blast method.

After his experiences with the TBM at the Hoosac tunnel, Wilson applied for a patent in 1875 for an improved version of the machine (Fig 1-3). This was based on a completely new design of cutting head; no longer was the entire face to be excavated with cutting tools, but only an external ring and a central hole. This was to be achieved by mounting disc cutters at the outer rim and the rotational axis of the cutting wheel. After reaching the maximum cut depth, the machine had to be withdrawn to enable the remaining core to be loosened using explosives. The advantage was the precise profile of the excavation. This type of excavation with outer groove and central drilled hole proved to work well and was also used for other early tunnel driving machines like that of Maus, and this type of excavation has also been used from time to time since.

Also in 1853, the same year as Wilson was testing his first machine in the Hoosac tunnel, the American Ebenezer Talbot developed a tunnelling machine, which worked using disc cutters and a rotating cutting wheel. But this construction had the disc cutters arranged in pairs on swinging arms on the cutting wheel (Fig. 1-4). The combination of the rotation of the cutting head and the movement of the cutting arms enabled the excavation of the entire face. Talbot's machine failed in the first tests boring a section of diameter 5.18 m. Looked at with modern eyes, it is possible to recognise in the arrangement of the disc cutters on cutting arms parallels to the System Bouygues (see Fig. 3-36) tunnelling machines used in the 1970s.

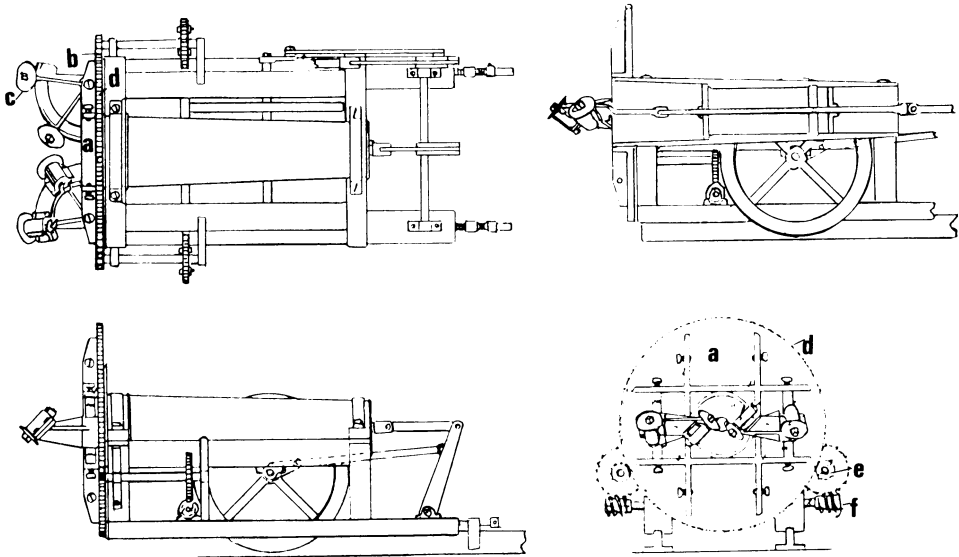

Figure 1-4
Tunnelling machine with drilling head and swinging cutting arms from E. Talbot, U.S. patent No. 9774, 1853 [159]

Cooke and Hunter (Wales) proposed an entirely new system with their patent from 1866 (Fig. 1-5). Instead of a cutting wheel turning about the tunnel centreline, three drums rotated about a horizontal axis transverse to the tunnel. The central drum had the largest diameter and ran ahead of the others, while the outer drums extended the cross section. The excavated section had a box shape with right-angled extensions. The direction of rotation was meant to clear the muck from the face during boring. The machine was never built, but the idea of a rotating extraction drum was found again fifty years later in tunnelling machines like the “Eiserner Bergmann” (*Iron Miner*) (see Fig. 1-8).

After Frederick E. B. Beaumont had already applied for a patent in 1863 for a tunnelling machine equipped with chisels and used this unsuccessfully for the construction of a water tunnel, he applied in 1875 for a patent for a tunnel boring machine with a rotating cutting wheel (Fig. 1-6).

The cutting wheel consisted a number of radial arms mounted on the end of a horizontal shaft. The tapered cutting arms were fitted with steel bits. The tip of the drilling bit formed a large conically ground chisel. The driving force was to be produced by a hydraulic pump driven by compressed air.

This patent was taken up by Colonel T. English and further developed for his own machine, for which he applied for a patent in 1880 [159]. There were cylindrical holes in the cutting arms for the drilling tools, into which chisel bits were screwed. The new idea of this construction was that the bits could be exchanged without having to withdraw the machine from the face. The arrangement of the bits on the two cutting arms was designed to cut concentric rings into the working face, so the remaining rock

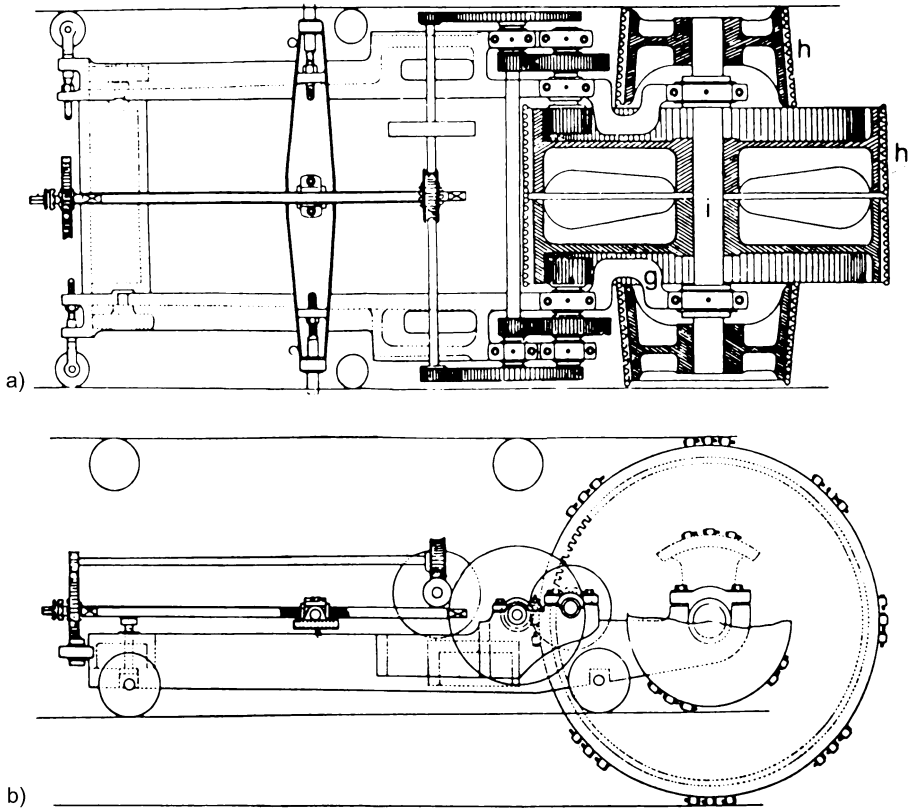
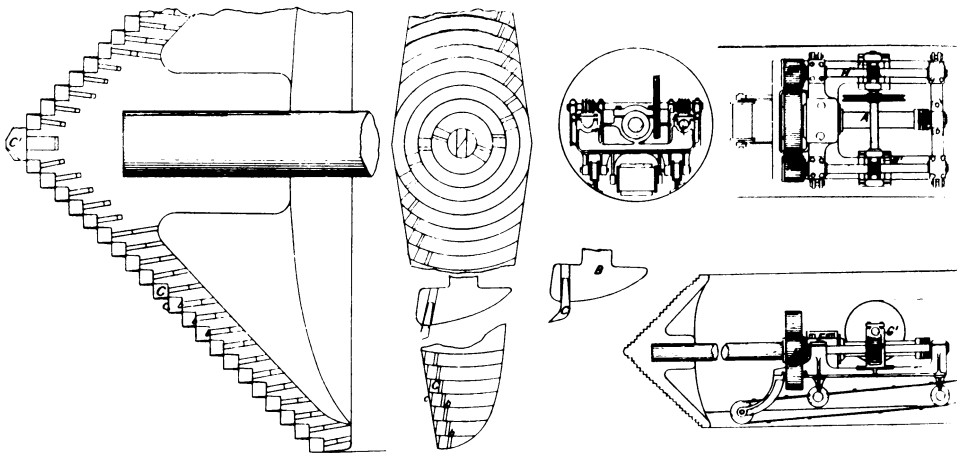

Figure 1-5
Tunnelling machine by Cooke and Hunter, U.K. patent No. 433, 1866 [159]



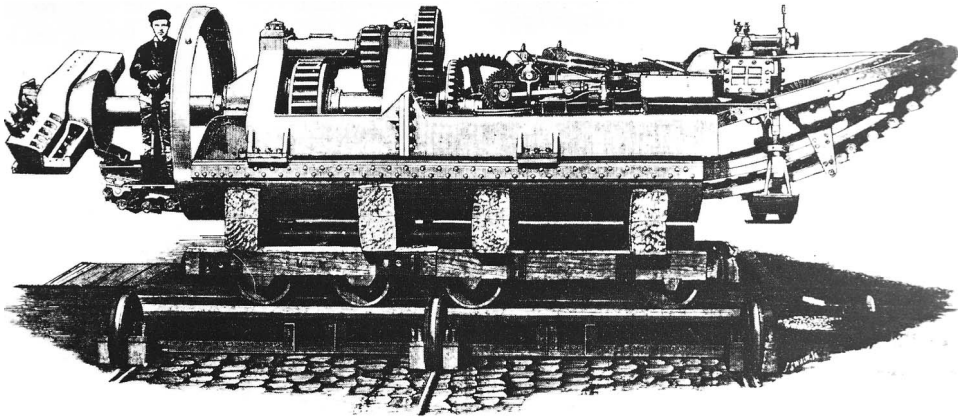

Figure 1-7
Tunnel boring machine by Beaumont/English, \varnothing 2.13 m, Channel Tunnel, 1882 [159]

between the grooves would break off during cutting. A lower frame formed the base frame of the machine with equipment to carry away the muck and the drive for the drilling head. An upper frame held the actual drilling equipment, which was pushed forward by a hydraulic cylinder. So it was possible for the first time to push the cutter head forward without releasing the bracing of the machine to the tunnel walls. This system allowed high blade pressure and is still a principle of modern TBMs.

Beaumont built two machines to the patent of Colonel T. English in 1881 and used them to drive the Channel Tunnel (Fig. 1-7). The machines worked there very successfully from 1882 until 1883, when the work was stopped for political reasons. Altogether 1,840 m were driven on the French side and 1,850 m on the English side. The maximum daily advance rate was 25 m, a considerable achievement for that time [100].

There was no further application of tunnelling machines in the next decades. They were, however, successfully used in mining for cutting relatively soft rock. In the first half of the 20th century, tunnelling machines were used for driving galleries in potash mines. The first version from 1916/1917, called the “Eiserner Bergmann”, had a rotating roller fitted with steel cutters as a cutting wheel, which on account of its dimensions produced rectangular sections (Fig. 1-8).

The next generation of gallery cutting machines built by Schmidt, Kranz & Co. from 1931 was more successful. The machine consisted of the main components drill carriage, bracing carriage, cable carriage and loading band (Fig. 1-9). The three-armed cutting wheel was fitted with needles and achieved on average advances of 5 m per shift. Five men were needed to operate the machine. The disadvantages of this machine, which was also used in Hungarian brown coal mining, were considered at the time to be the size, the weight, the poor mobility and the time wasted bringing the machine back. In practice, the machine was used for quickly driving investigation and ventilation headings. The similarity to the TBM built by Whittaker for the Channel Tunnel in the

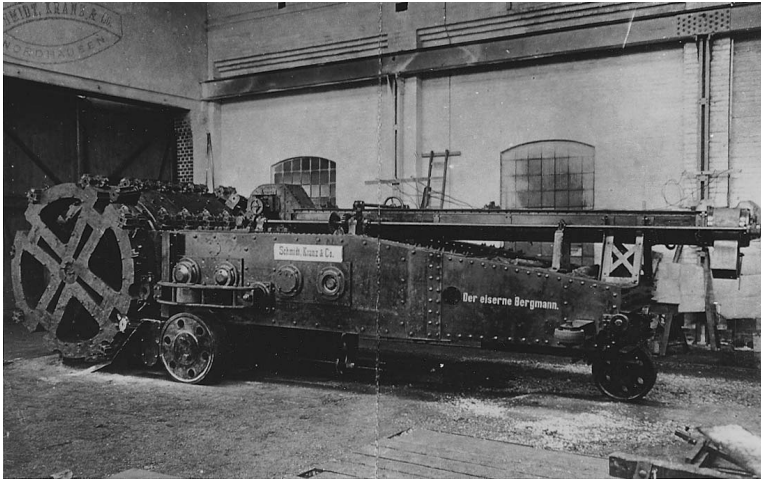

Figure 1-8
Gallery driving machine “Eiserner Bergmann” 1916/17 from Schmidt, Kranz et al. [145]

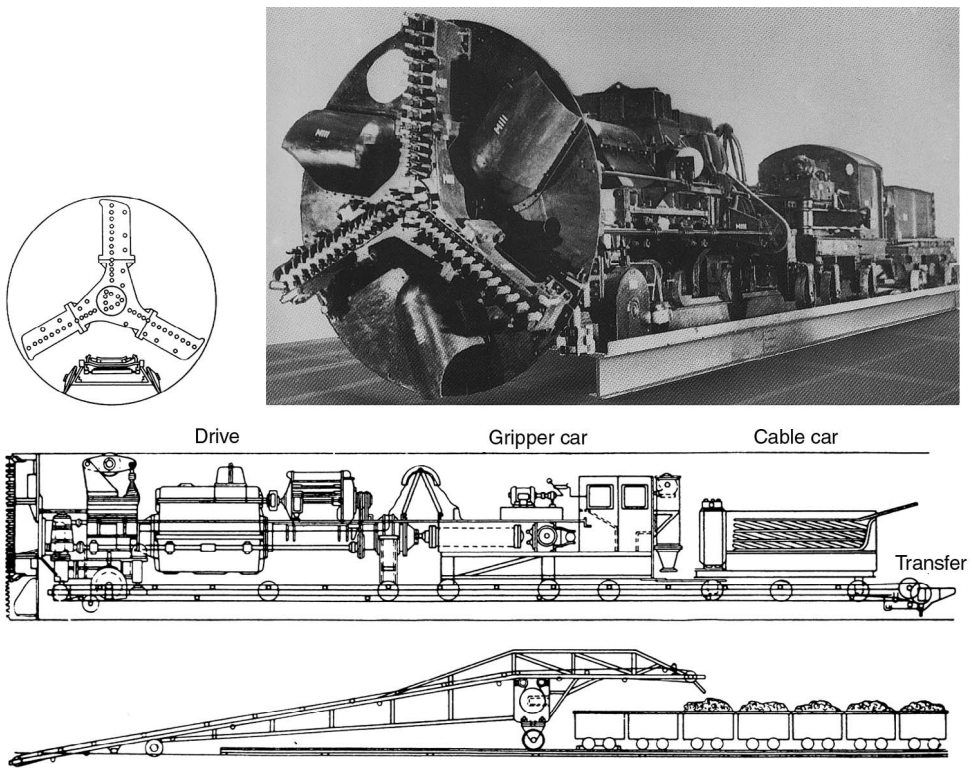

Figure 1-9
Gallery cutting machine from Schmidt, Kranz et al., \varnothing 3 m, 1931 [114, 145]

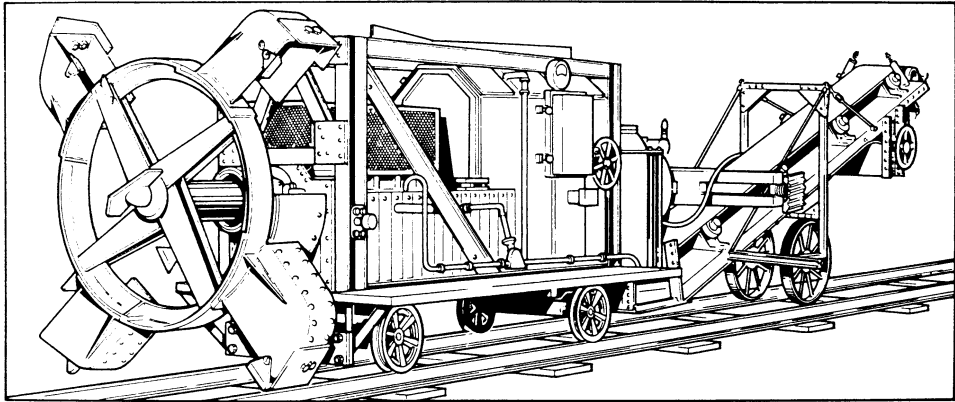
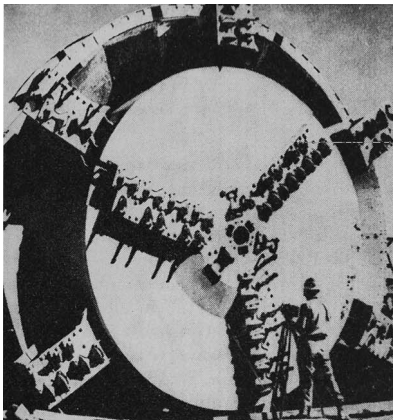

Figure 1-10
Tunnel boring machine by Whitaker, \varnothing 3.6 m, 1922 [72]

1920s is noticeable (Fig. 1-10). This achieved an average advance speed of 2.7 m/h in a test heading in the lower chalk near Folkestone.

The breakthrough to the development of today's TBMs did not occur until the 1950s, when the first open gripper TBM with disc cutters as its only tools was developed by the mining engineer James S. Robbins. Preliminary tests driving the Humber sewer tunnel in Toronto showed that, with only disc cutters and with considerably greater working life, the same advance performance could be achieved as with the intended combination of hard metal cutters and discs of the former TBM. Using this TBM in the Humber sewer tunnel, advances



a)

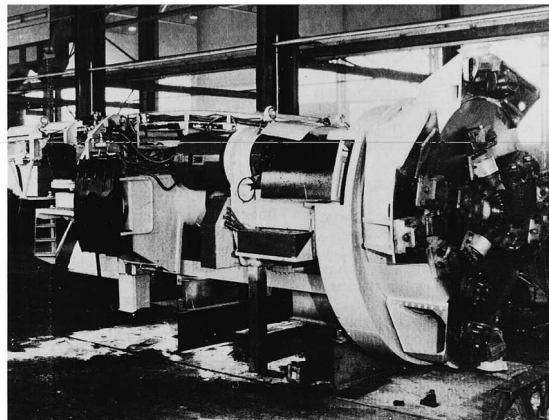

b)

Figure 1-11
Tunnel boring machines from Robbins [125]
a) First Robbins TBM, model 910-101, Oahe Damm, \varnothing 8.0 m, 1953
b) First modern gripper TBM von J.S. Robbins, model 131-106, Humber River sewer tunnel (Toronto, Canada) \varnothing 3.27m, 1957 (Robbins)

of up to 30 m/d were achieved in sandstone, limestone and clay (Fig. 1-11 a). Mechanical tunnelling at this time was primarily concentrated on stable and relatively soft rock. With the growing success of Robbins, further American manufacturers like Hughes, Alkirk-Lawrence, Jarva and Williams began building tunnel boring machines. Machine types still current today like the main beam TBM or the kelly TBM had their origins at this time.

After a slight delay, the development of tunnelling machines was also taken up in Europe. At first, however, different avenues of development were followed. Based on experience in Austrian brown coal mining with the Czech Bata machine [114], The Austrian engineer Wohlmeyer developed undercutting technology with rotating milling wheels (Fig. 1-12 a). This technology did not catch on, and nor did that used by the Bade company with the cutting head divide into three contra-rotating rings fitted with

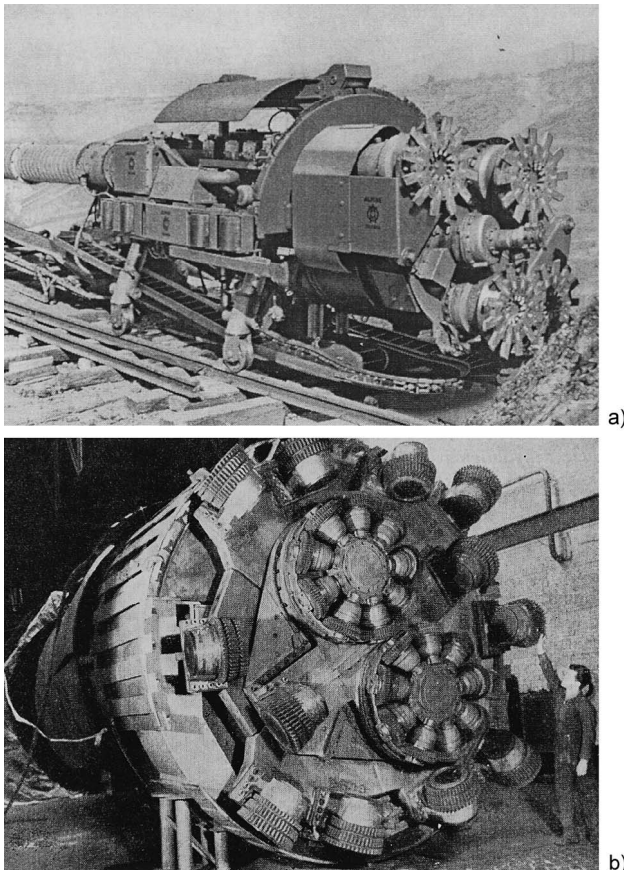

Figure 1-12

First European developments of tunnelling machines [170]

a) Wohlmeyer gallery cutting machine SBM 720

(Österreichisch Alpine Montan-Gesellschaft), \varnothing 3 m, 1958

b) Tunnel boring machine SVM 40 (Bade), operating in coal mining industry, \varnothing 4 m, 1961

toothed roller borers, which were already outdated at the time of the trial (Fig. 1-12b). Both types of machine were unsuccessful in tests in the hard rock of the Ruhr, although other Wohlmeyer machines were used successfully for the Albstollen heading and in the subsidiary headings of the Seikan tunnel [18, 45, 170]. Undercutting technology has been used and further developed over many decades by various manufacturers like Habegger, AtlasCopco, Krupp, IHI and Wirth because of the low thrust force required and the ability to drive non-circular cross-sections. The separation of the Bade TBM into a front section with cutting head and a rear section, which was hydraulically braced by four large pressure plates against the tunnel sides to provide reaction for the boring head carrier, and which is withdrawn after the completed travel of the advance cylinder, is however recognisable in modern double shield machines.

In the 60s, German manufacturers like Demag and Wirth began building tunnel boring machines of North American type. These machines were mainly intended to bore hard rock. Drilling tools from deep boring technology like TCI or toothed bits were mounted on the drilling heads. The developing technology for hardening the disc cutters enabled the use of this type of tool in really hard rock. At the end of the 60s, inclined headings and large tunnel sections were driven for the first time using the reaming method, the development of reamer boring being closely associated with the Murer company (Fig. 1-13).

Progress in the 70s and 80s was directed towards driving in brittle rock and the enlargement of tunnel sections, with the consideration of the stand-up time of the soil/rock becoming particularly important. Encouraged by the successful implementation of a gripper TBM for the Mangla dam project in 1963 with a diameter of 11.17 m, a gripper TBM was also used for the construction of the Heitersberg tunnel (\varnothing 10,65 m) in Switzerland in 1971. The work necessary to secure the rock with steel installation,

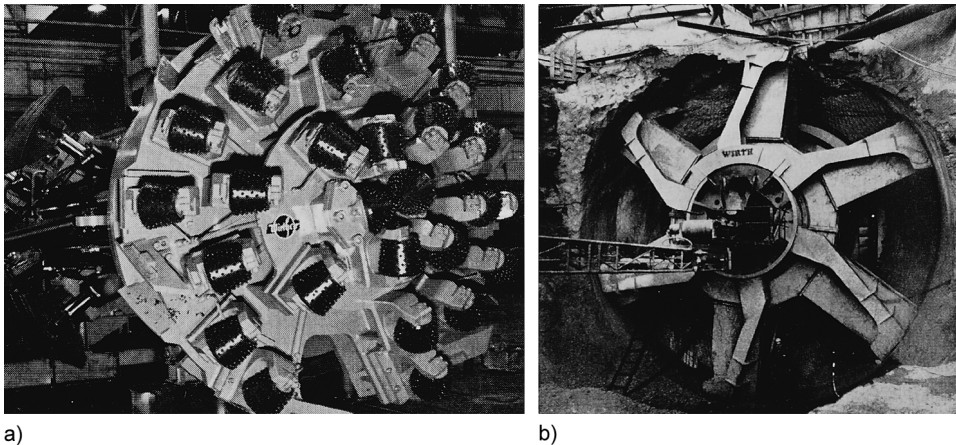

Figure 1-13

Special types of Wirth Tunnel boring machines [182]

- a) Inclined heading TBM TB II-300 E Emossion pressure tunnel, \varnothing 3 m, 1968 (Wirth)
- b) Enlargement TBM TBE 770/1046 H Sonnenberg tunnel, \varnothing 7.70 m/10.46 m, 1969 (Wirth)

anchors and mesh-reinforced shotcrete however made the hoped-for advance impossible. The required adaptation to the large cross-section was first achieved in 1980 by the modification of the Robbins gripper machine from the Heitersberg tunnel by the Locher und Prader company to a shielded TBM with segmental lining for the advance of the Gubrist tunnel (\varnothing 11,50 m) (Fig. 1-14 a). Robbins and Herrenknecht have made shield machines of this type in diameters from 11–12.5 m.

At the same time, Carlo Grandori developed the concept of the double shield TBM and, in collaboration with Robbins, put it into practice for the building of the Sila pressure tunnel (\varnothing 4,32 m) in Italy (Fig. 1-14 b). The main intention of the development of this

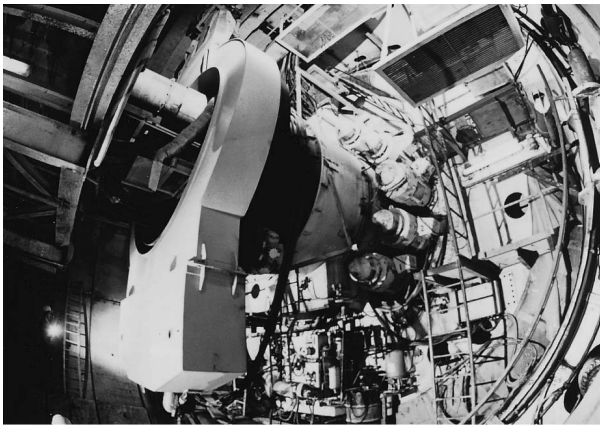

a)

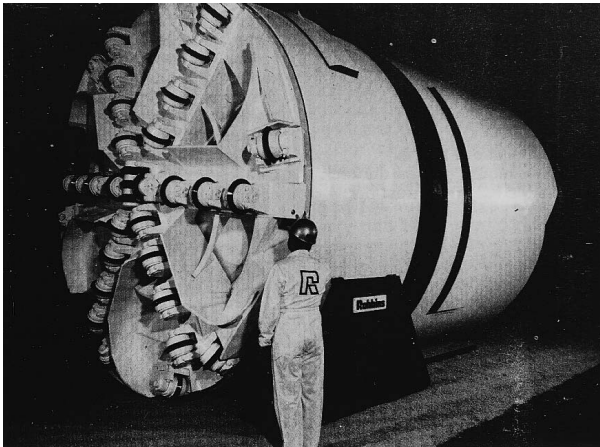

b)

Figure 1-14

Tunnel boring machine with shield

a) Single shield TBM, Gubrist tunnel, \varnothing 11.50 m, 1980 (Locher/Prader [144])

b) Double shield TBM 144-151, Sila pressure tunnel, \varnothing 4.32 m, 1972 (Robbins [52])

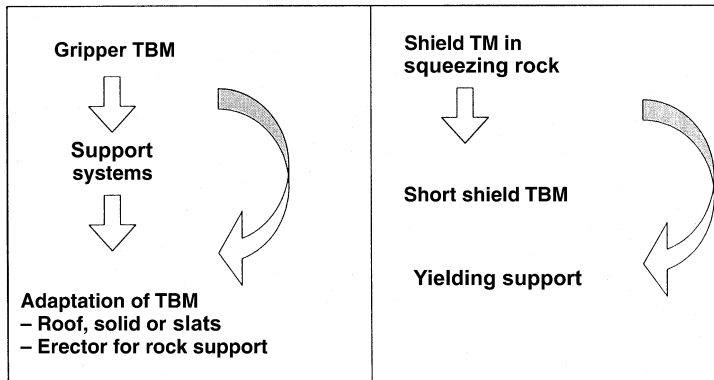

Figure 1-15
Postulated innovation path

machine was to make the gripper TBM, which had then already proved very effective in appropriate geological conditions, more flexible for use in heterogeneous rock conditions. Since their first use in 1972 and the successful modification of this type of machine, double shield TBMs with customised segmental lining designs have achieved high advance rates under favourable rock conditions and have been made by all the well-known manufacturers, mainly in the medium diameter range. The capability of the double shield TBM design was demonstrated impressively at the end of the 80s in the chalk of the Channel Tunnel, which is favourable for tunnelling. [100].

Alongside the development of the TBM with shield, the manufacturers of open gripper TBMs began to investigate possibilities of improving their machines to enable any necessary lining to be installed earlier. Shotcrete around the machine was tested. The state of progress with large diameter TBMs today is the installation of lining elements immediately behind the boring shield or partial areas of the shield and the systematic installation of rock anchors. With smaller tunnel boring machines, the body of the machine obstructs the installation of lining around the machine using mechanical equipment with the result that where lining has to be installed quickly, this has to be done by hand with a corresponding reduction of the advance rate.

The development of gripper TBMs at the moment is to enable the early mechanical installation of the lining around the machine in order to improve the boring performance by reducing the time taken to install the measures to secure the tunnel sides. Further reductions of the boring time would only lead to a marginal increase of advance rates, as today's TBMs already have availability rates of 80–90%.

For future development of tunnel driving with gripper TBMs, it is necessary to adapt the design of linings intended for conventional tunnelling to the special requirements of TBM tunnelling. The fear of a shield TBM jamming fast, which is repeatedly expressed, and the problem of rigid lining also demand innovative developments, although no such case is known for relevant single-shield TBMs.

The route from the ancestors of the modern TBM described here to modern high-technology machines was long, often arduous and even dangerous. To describe the early designs individually in more detail would exceed the space available for this book. Interested readers are recommended the reference book by Barbara Stack [159], which goes into the history of patents in TBM tunnelling in detail. Current developments and innovations are dealt with extensively in the following chapters.

