

FRANCIS D.K.
CHING

BARRY S. ONOUYE
DOUGLAS ZUBERBUHLER

BUILDING
STRUCTURES
ILLUSTRATED

PATTERNS, SYSTEMS,
AND DESIGN

SECOND EDITION



WILEY

Building Structures ILLUSTRATED

Building Structures ILLUSTRATED

Second Edition

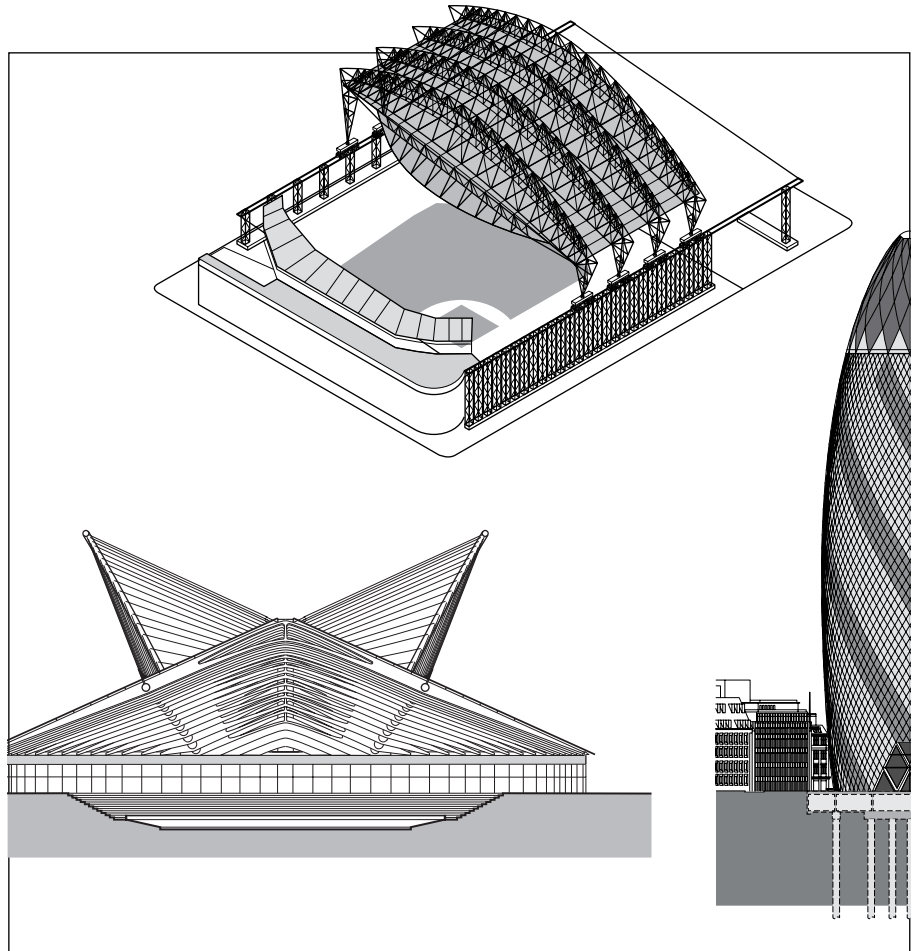

Francis D. K. Ching
Barry Onouye
Douglas Zuberbuhler

WILEY

Cover Design: Wiley

Cover Image: courtesy of Francis D.K. Ching

This book is printed on acid-free paper. 

Copyright © 2014 by John Wiley & Sons, Inc. All rights reserved

Published by John Wiley & Sons, Inc., Hoboken, New Jersey

Published simultaneously in Canada

No part of this publication may be reproduced, stored in a retrieval system, or transmitted in any form or by any means, electronic, mechanical, photocopying, recording, scanning, or otherwise, except as permitted under Section 107 or 108 of the 1976 United States Copyright Act, without either the prior written permission of the Publisher, or authorization through payment of the appropriate per-copy fee to the Copyright Clearance Center, 222 Rosewood Drive, Danvers, MA 01923, (978) 750-8400, fax (978) 646-8600, or on the web at www.copyright.com. Requests to the Publisher for permission should be addressed to the Permissions Department, John Wiley & Sons, Inc., 111 River Street, Hoboken, NJ 07030, (201) 748-6011, fax (201) 748-6008, or online at www.wiley.com/go/permissions.

Limit of Liability/Disclaimer of Warranty: While the publisher and author have used their best efforts in preparing this book, they make no representations or warranties with the respect to the accuracy or completeness of the contents of this book and specifically disclaim any implied warranties of merchantability or fitness for a particular purpose. No warranty may be created or extended by sales representatives or written sales materials. The advice and strategies contained herein may not be suitable for your situation. You should consult with a professional where appropriate. Neither the publisher nor the author shall be liable for damages arising herefrom.

For general information about our other products and services, please contact our Customer Care Department within the United States at (800) 762-2974, outside the United States at (317) 572-3993 or fax (317) 572-4002.

Wiley publishes in a variety of print and electronic formats and by print-on-demand. Some material included with standard print versions of this book may not be included in e-books or in print-on-demand. If this book refers to media such as a CD or DVD that is not included in the version you purchased, you may download this material at <http://booksupport.wiley.com>. For more information about Wiley products, visit www.wiley.com.

Library of Congress Cataloging-in-Publication Data:

Ching, Frank, 1943-

Building structures illustrated : patterns, systems, and design

/ Francis D.K. Ching, Barry Onouye, Doug Zuberbuhler.

p. cm.

Includes bibliographical references and index.

ISBN 978-1-118-45835-8 (pbk.); 978-1-118-80823-8 (ebk); 978-1-118-84830-2 (ebk)

1. Structural design. 2. Buildings. I. Onouye, Barry. II. Zuberbuhler, Doug. III. Title.

TA658.C49 2009

624.1'771--dc22

2008047061

Printed in the United States of America.

10 9 8 7 6 5 4 3 2 1

Contents

Preface...vii

- 1 Building Structures...1**
- 2 Structural Patterns...39**
- 3 Horizontal Spans...89**
- 4 Vertical Dimensions...147**
- 5 Lateral Stability...197**
- 6 Long-Span Structures...235**
- 7 High-Rise Structures...277**
- 8 Systems Integration...305**

Bibliography...335

Index...337

Disclaimer

While this publication is designed to provide accurate and authoritative information regarding the subject matter covered, it is sold with the understanding that neither the publisher nor the authors are engaged in rendering professional services. If professional advice or other expert assistance is required, the services of a competent professional person should be sought.

Preface

Many reputable books are available that cover the subject of building structures, from ones focusing on statics and strength of materials to others dealing with the design and analysis of structural elements, such as beams and columns, and still others covering specific structural materials. An understanding of the behavior of structural elements under different load conditions is critical to professionals, as is the ability to select, size, and shape appropriate structural materials and their connections. This book assumes the accessibility of these valuable resources and focuses instead on building structures as systems of interrelated parts for creating and supporting the habitable environments we call architecture.

A principal characteristic of this text is its holistic approach to building structures. Beginning with a concise review of how structural systems have evolved over time, the text discusses the idea of structural patterns and how these patterns of supports and spans can not only sustain but reinforce an architectural idea. The core of this book is an examination of the horizontal spanning and vertical support systems that house our activities and contribute to the vertical dimensions of form and space. The discussion then turns to a review of the critical aspects of lateral forces and stability, the unique properties of long-span structures, and current strategies for high-rise structures. The final chapter is a brief but important review of the integration of structural and other building systems.

While this text deliberately avoids a strictly mathematical approach to building structures, it does not neglect the fundamental principles that govern the behavior of structural elements, assemblies, and systems. To better serve as a guide during the preliminary design process, the discussion is accompanied by numerous drawings and diagrams that instruct and perhaps even inspire ideas about how a structural pattern might inform a design concept. The challenge in design is always how to translate principles into action. The major change in this second edition, therefore, is the addition of examples that illustrate the ways in which structural principles can be manifested in examples of real-world architecture.

The authors hope that this richly illustrated work will serve as a desktop resource for design students as well as young professionals and help them view structural systems as essential and integral to the design and building process.

Metric Equivalents

The International System of Units is an internationally accepted system of coherent physical units, using the meter, kilogram, second, ampere, kelvin, and candela as the base units of length, mass, time, electric current, temperature, and luminous intensity. To reinforce an understanding of the International System of Units, metric equivalents are provided throughout this book according to the following conventions:

- All whole numbers in parentheses indicate millimeters unless otherwise noted.
- Dimensions 3 inches and greater are rounded to the nearest multiple of 5 millimeters.
- Note that $3487 \text{ mm} = 3.487 \text{ m}$.
- In all other cases, the metric unit of measurement is specified.

1

Building Structures

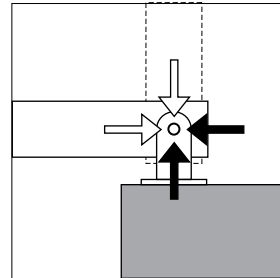
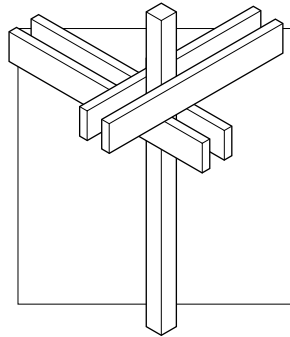
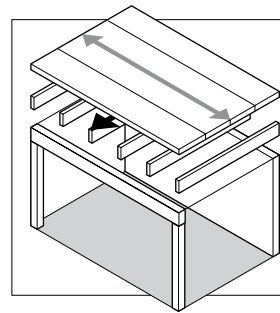
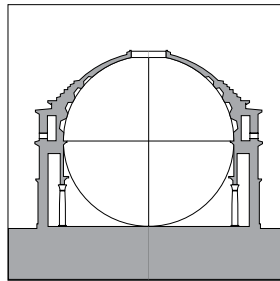

BUILDING STRUCTURES

Buildings—the relatively permanent constructions we erect on a plot of land for habitable use—have developed over the course of history from simple shelters constructed of sticks, mud-brick, and stones to the more sophisticated constructions of concrete, steel, and glass of today. Throughout this evolution of building technology, what has remained constant is the enduring presence of some form of structural system capable of withstanding the forces of gravity, wind, and oftentimes, earthquakes.

We can define a structural system as a stable assembly of elements designed and constructed to function as a whole in supporting and transmitting applied loads safely to the ground without exceeding the allowable stresses in the members. While the forms and materials of structural systems have evolved with advances in technology and culture, not to mention the lessons learned from numerous building failures, they remain essential to the existence of all buildings, no matter their scale, context, or use.

The brief historical survey that follows illustrates the development of structural systems over time, from the earliest attempts to satisfy the fundamental human need for shelter against sun, wind, and rain, to the longer spans, greater heights, and increasing complexity of modern architecture.

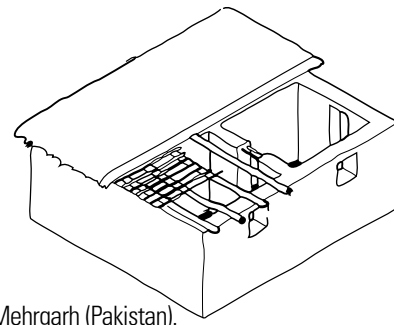

6500 BC: Mehrgarh (Pakistan).
Compartmentalized mud-brick structures.

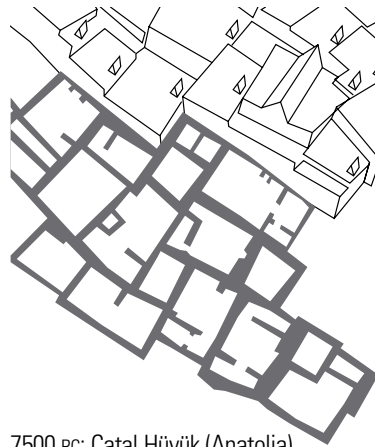

7500 BC: Catal Hüyük (Anatolia).
Mud-brick houses with plastered interior walls.

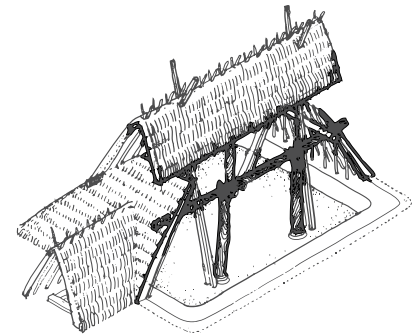

5000 BC: Banpo, China. Pit-style houses using thick pillars to support their roofs.

5000 BC

Bronze Age

The Neolithic period dawned with the advent of farming c. 8500 BC and transitioned to the early Bronze Age with the development of metal tools c. 3500 BC. The practice of using caves for shelter and dwelling had already existed for millennia and continued to develop as an architectural form, ranging from simple extensions of natural caves to carved out temples and churches to entire towns carved into the sides of the mountains.

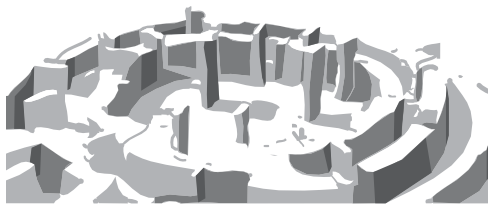

9000 BC: Göbekli Tepe (Turkey). The world's oldest known stone temples.

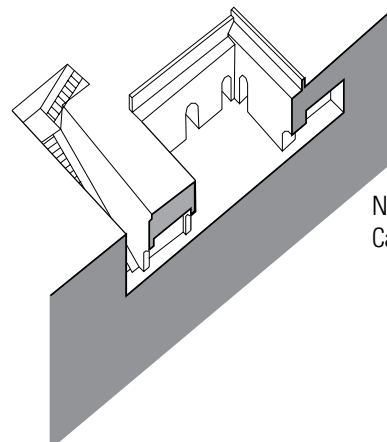

Neolithic Age: China, Northern Shaanxi province.
Cave dwelling continues to the present day.

3400 BC: Sumerians introduce kilns.

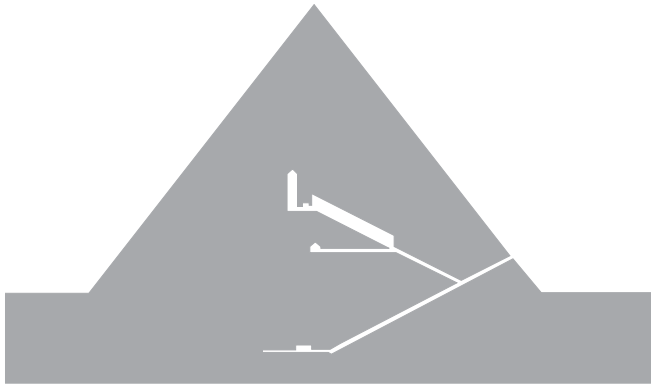

2500 BC: Great Pyramid of Khufu, Egypt. Until the 19th century, this stone pyramid was the tallest structure in the world.

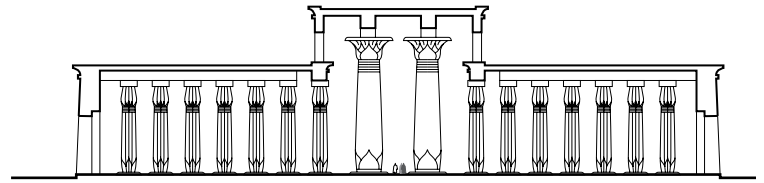

1500 BC: Temple of Amun at Karnak, Egypt. Hypostyle Hall is a stellar example of trabeated (column-and-beam) stone construction.



2600 BC: Harappa and Mohenjo-daro, Indus Valley, modern-day Pakistan and India. Fire-baked bricks and corbeled arches.

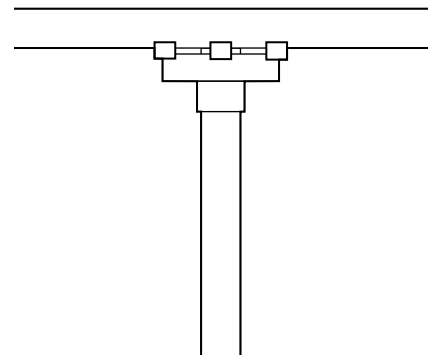

12th century BC: Zhou Dynasty architecture. Corbel brackets (dougong) on column heads help support projecting eaves.

2500 BC

1000 BC

Iron Age

While cave dwelling endures in various forms in different parts of the world, most architecture is created by assembling materials to define the limits of space as well as to provide shelter, house activities, commemorate events, and signify meaning. Early houses consisted of rough timber frames with mud-brick walls and thatched roofing. Sometimes pits were dug in the earth to provide additional warmth and protection; at other times, dwellings were elevated on stilts for ventilation in warm, humid climates or to rise above the shores of rivers and lakes. The use of heavy timber for the structural framing of walls and roof spans continued to develop over time and was refined, especially in the architecture of China, Korea, and Japan.

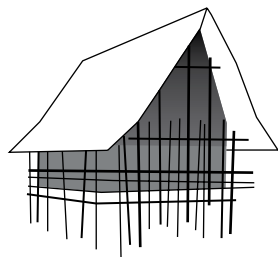

3000 BC: Alvastra (Scandinavia). Houses raised on wood stilts.

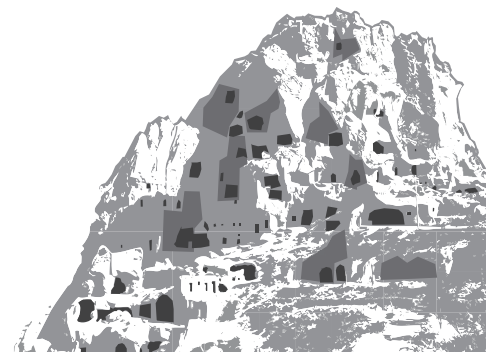

1000 BC: Cappadocia, Anatolia. Extensive excavations formed houses, churches, and monasteries.

3000 BC: Egyptians mix straw with mud to bind dried bricks.

1500 BC: Egyptians work molten glass.

1350 BC: Shang Dynasty (China) develops advanced bronze casting.

A HISTORICAL SURVEY

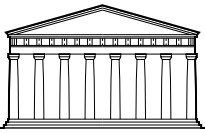

447 BC: Parthenon, Athens. This Temple of Athena is considered to be a paragon of the Doric order.

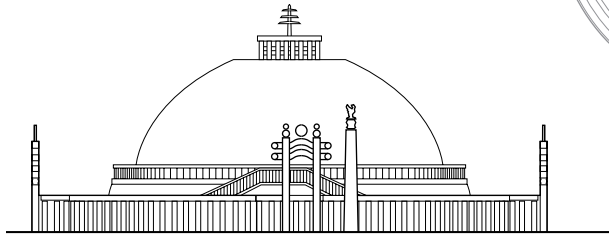
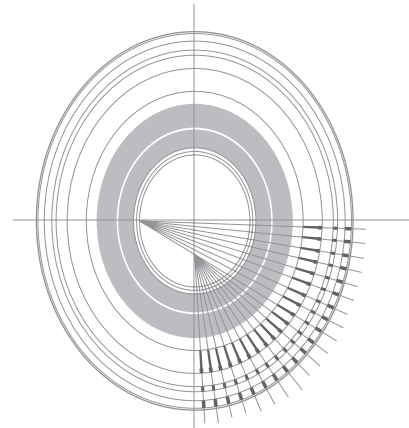

3rd century BC: Great Stupa at Sanchi, India. Carved stone Buddhist monument.

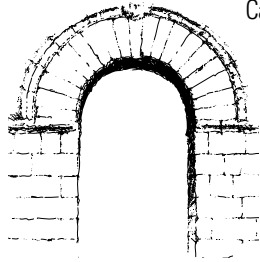
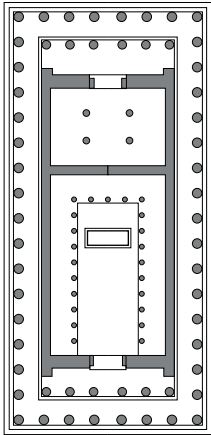

4th century BC: Etruscans develop the masonry arch and vault. Porta Pulchra, Perugia.

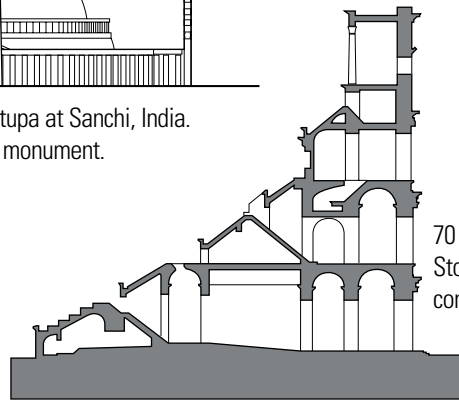

70 AD: Colosseum, Rome. Stone-faced brick and concrete amphitheater.

500 BC

1 AD

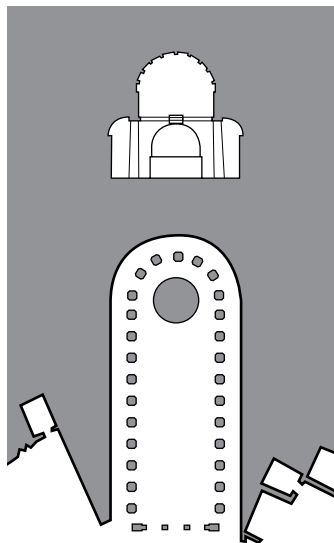

200 BC: India. Numerous examples of Buddhist, Jain, and Hindu cave architecture.



10 BC: Petra, Jordan. Palace tombs half-built, half-carved into the rock.

5th century BC: Chinese cast iron.

4th century BC: Babylonians and Assyrians use bitumen to bind bricks and stones.

3rd century BC: Romans make concrete with pozzolanic cement.

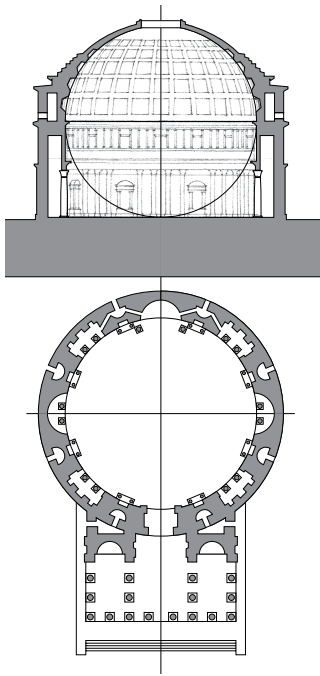

125 AD: The Pantheon, Rome. Coffered concrete dome largest in the world until 18th century.

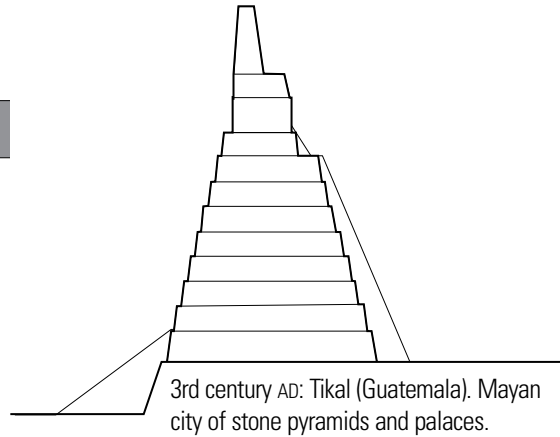

3rd century AD: Tikal (Guatemala). Mayan city of stone pyramids and palaces.

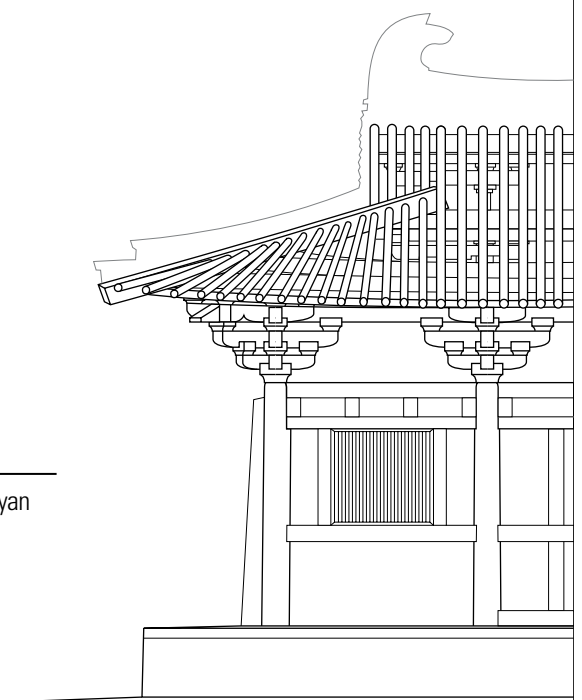

7th century AD: Tang Dynasty architecture. Earthquake-resistant timber framework comprised columns, beams, purlins, and a multitude of corbel brackets.

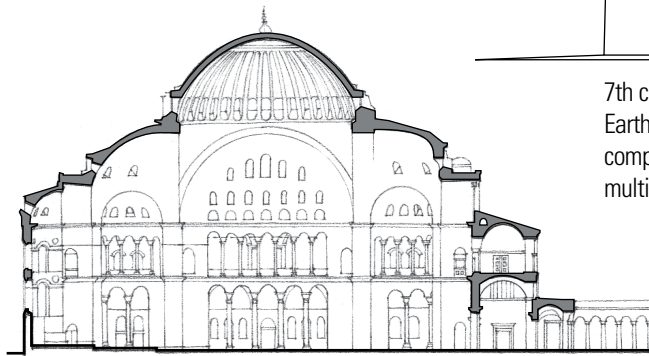

800 AD

532–37 AD: Hagia Sophia, Istanbul. Central dome carried on pendentives that enable the transition from round dome to square plan. Concrete is used in the construction of the vaulting and arches of the lower levels.



460 AD: Yungang Grottoes, China. Buddhist temples carved into sandstone cliffs.



752 AD: Todaiji, Nara. Buddhist temple is world's largest wooden building; present reconstruction is two-thirds of the original temple's size.

2nd century AD: Paper is invented in China.

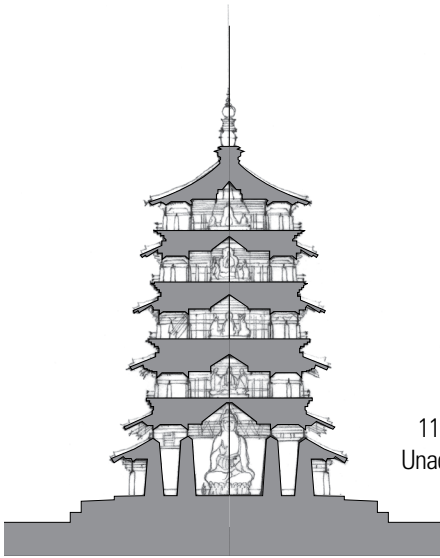

1056: Sakyamuni Pagoda, China. Oldest surviving timber pagoda and tallest timber building in the world at a height of 220 feet (67.1 m).

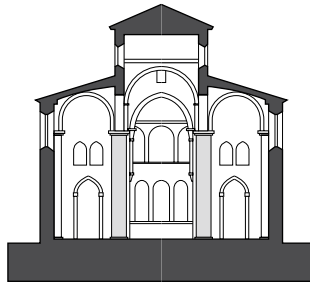

11th century: Abbey church of St-Philibert, Tournus. Unadorned cylindrical pillars more than 4 feet (1.2 m) thick support the spacious and light nave.

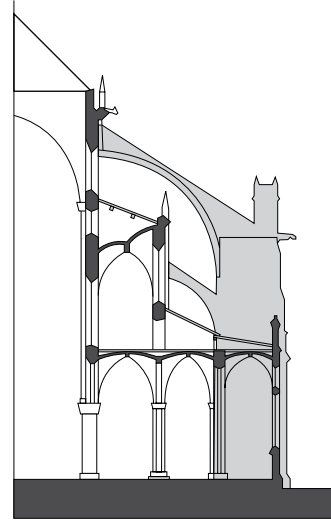

1163–1250: Notre Dame Cathedral, Paris. Cut stone structure utilizes external flying buttresses to transmit the outward and downward thrust from a roof or vault to a solid buttress.

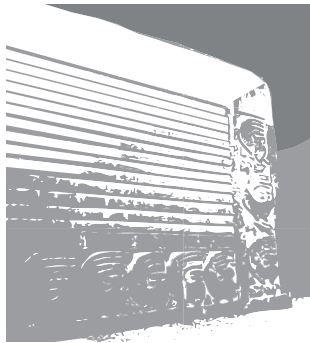

1100: Chan Chan. Citadel walls of stucco-covered mud-brick.

900 AD

Where stone was available, it was first used to establish defensive barriers and serve as bearing walls to support timber spans for floors and roofs. Masonry vaulting and domes led to higher elevations and greater spans, while the development of pointed arches, clustered columns, and flying buttresses enabled the creation of lighter, more open, skeletal stone structures.



1100: Lalibela, Ethiopia. Site of monolithic, rock-cut churches.

1170: Cast iron is produced in Europe.

15th century: Filippo Brunelleschi develops theory of linear perspective.

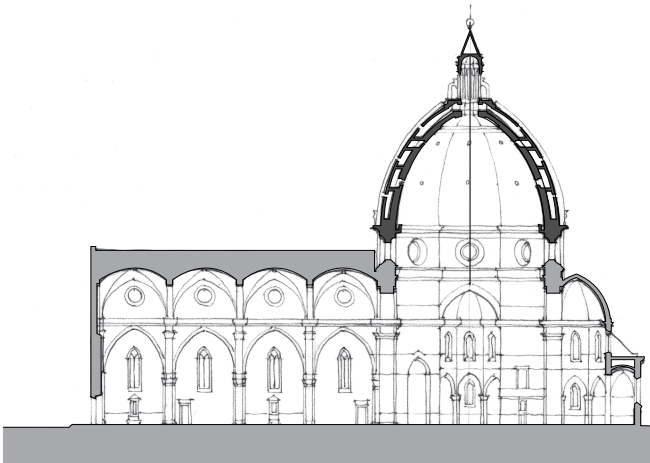

13th century: Cathedral of Florence, Italy. Filippo Brunelleschi designed the double-walled dome, resting on a drum, to allow it to be built without the need for scaffolding from the ground.



1506–1615: St. Peter's Basilica, Rome, Donato Bramante, Michelangelo, Giacomo della Porta. Until recently the largest church ever built, covering an area of 5.7 acres (23,000 m²).

1400 AD

As early as the 6th century AD the main arcades of Hagia Sophia in Istanbul incorporated iron bars as tension ties. During the Middle Ages and the Renaissance, iron was used for both decorative and structural components, such as dowels and ties, to strengthen masonry structures. But it was not until the 18th century that new production methods allowed cast and wrought iron to be produced in large enough quantities to be used as a structural material for the skeletal structures of railway stations, market halls, and other public buildings. The mass of stone walls and columns transitions to the lighter imprint of iron and steel frames.

1600 AD

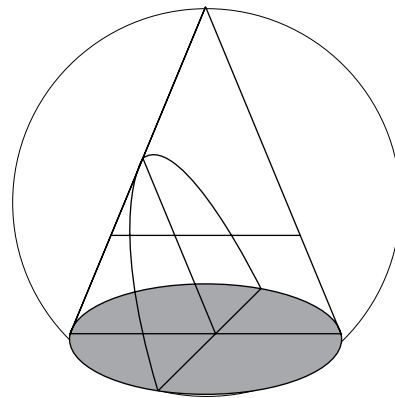

1638: Galileo publishes his first book, *The Discourses and Mathematical Demonstrations Relating to Two New Sciences*, the two sciences referring to the strength of materials and the motion of objects.

Early-16th century: Blast furnaces are able to produce large quantities of cast iron.

1687: Isaac Newton publishes *Philosophiæ Naturalis Principia Mathematica*, which describes universal gravitation and the three laws of motion, laying the groundwork for classical mechanics.



1653: Taj Mahal, Agra, India. Ahmad Lahauri. Iconic white-domed, marble mausoleum built in memory of Mumtaz Mahai, wife of Mughal Emperor Shah Jahan.

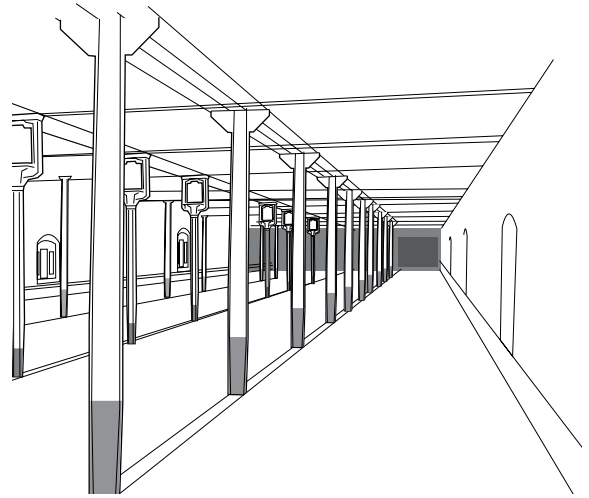

1797: Ditherington Flax Mill, Shrewsbury, England, William Strutt. Oldest steel-framed building in the world, having a structural frame of cast iron columns and beams.

1700

1800

Late-18th and early-19th centuries: The Industrial Revolution introduces major changes in agriculture, manufacturing, and transportation that alter the socioeconomic and cultural climate in Britain and elsewhere.

Central heating was widely adopted in the early-19th century when the Industrial Revolution caused an increase in the size of buildings for industry, residential use, and services.

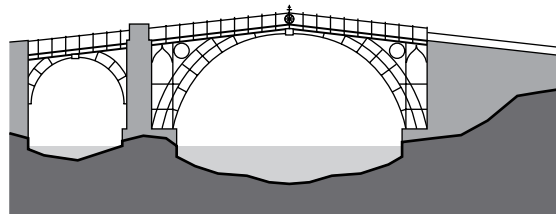

1777–79: Iron Bridge at Coalbrookdale, England. T. M. Pritchard.

1711: Abraham Darby produces high-quality iron smelted with coke and molded in sand.

1801: Thomas Young studies elasticity and gives his name to the elastic modulus.

1735: Charles Maria de la Condamine finds rubber in South America.

1778: Joseph Bramah patents a practical water closet.

1738: Daniel Bernoulli relates fluid flow to pressure.

1779: Bry Higgins patents hydraulic cement for exterior plaster.

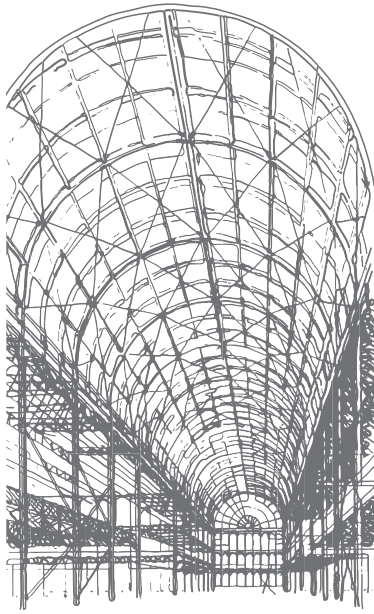

1851: Crystal Palace, Hyde Park, London, John Paxton. Prefabricated units of wrought iron and glass were assembled to create 990,000 square feet (91,974 m²) of exhibition space.

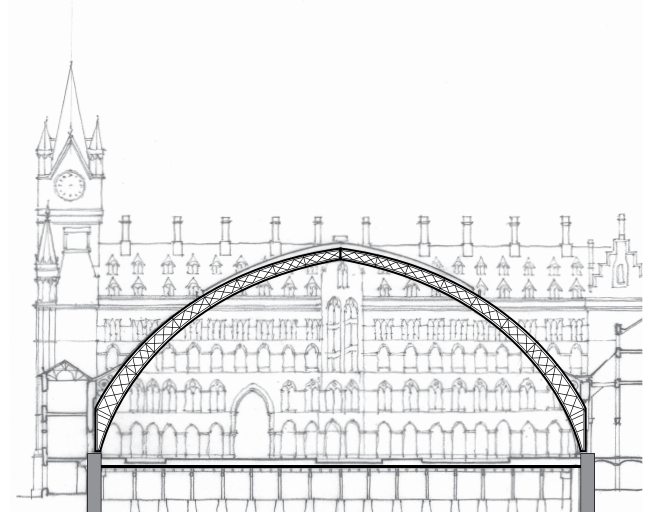

1868: St. Pancras Station, London, William Barlow. Trussed arch structure with tie rods below floor level to resist outward thrust.

1860

There is evidence that the Chinese used a mixture of lime and volcanic ash to build the pyramids of Shaanxi several thousand years ago, but it was the Romans who developed a hydraulic concrete from pozzolanic ash similar to the modern concrete made from Portland cement. The formulation of Portland cement by Joseph Aspdin in 1824 and the invention of reinforced concrete, attributed to Joseph-Louis Lambot in 1848, stimulated the use of concrete for architectural structures.

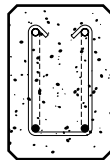

The modern era in steelmaking began when Henry Bessemer described a process for mass-producing steel relatively cheaply in 1856.

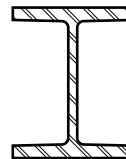

1850: Henry Waterman invents the lift.

1853: Elisha Otis introduces the safety elevator to prevent the fall of the cab if the cable is broken. The first Otis elevator is installed in New York City in 1857.

1824: Joseph Aspdin patents the manufacture of Portland cement.

1827: George Ohm formulates the law relating current, voltage, and resistance.

1855: Alexander Parkes patents celluloid, the first synthetic plastic material.

1867: Joseph Monier patents reinforced concrete.

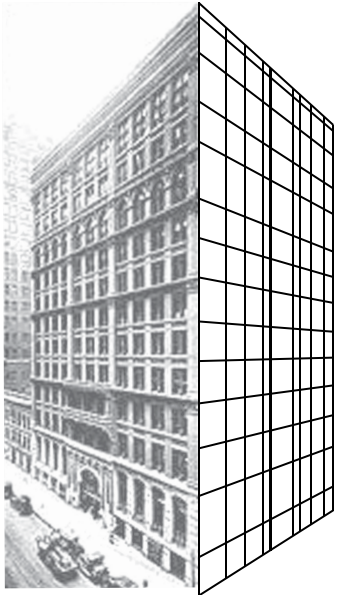

1884: Home Insurance Building, Chicago, William Le Baron Jenney. The 10-story structural frame of steel and cast iron carries the majority of the weight of the floors and exterior walls.



1889: Eiffel Tower, Paris, Gustave Eiffel. The Tower replaced the Washington Monument as the world's tallest structure, a title it retained until the Chrysler Building in New York City was erected in 1930.

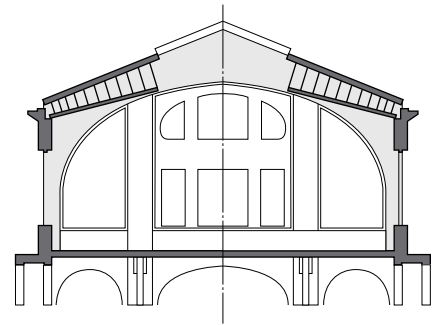

1898: Public Natatorium, Gebweiler, France, Eduard Züblin. Reinforced concrete roof vault consists of five rigid frames with thin plates spanning between each frame.

1875

1900

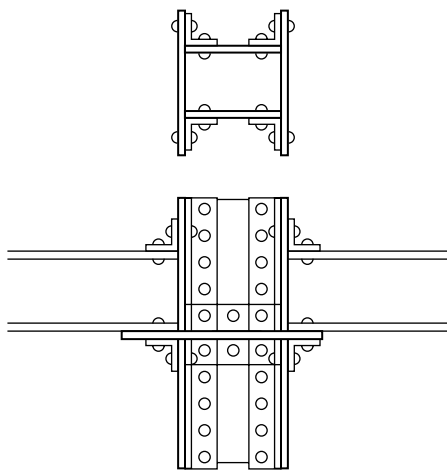

1881: Charles Louis Strobel standardizes rolled wrought-iron sections and riveted connections.

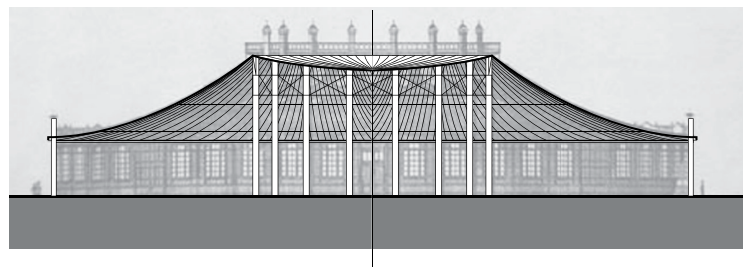

1896: Rotunda-Pavilion, All-Russia Industrial and Art Exhibition, Nizhny Novgorod, Vladimir Shukhov. The world's first steel tensile structure.



1903: Ingalls Building, Cincinnati, Ohio, Elzner & Anderson. First reinforced concrete high-rise building.

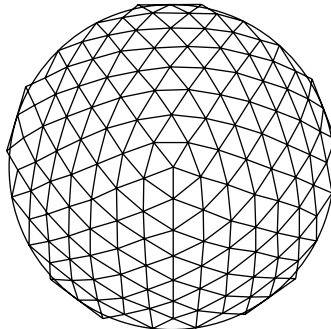
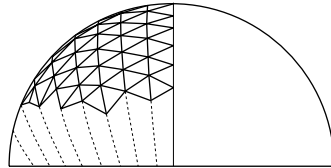

1922: Planetarium, Jena, Germany, Walter Bauerfeld. First contemporary geodesic dome on record, derived from the icosahedron.

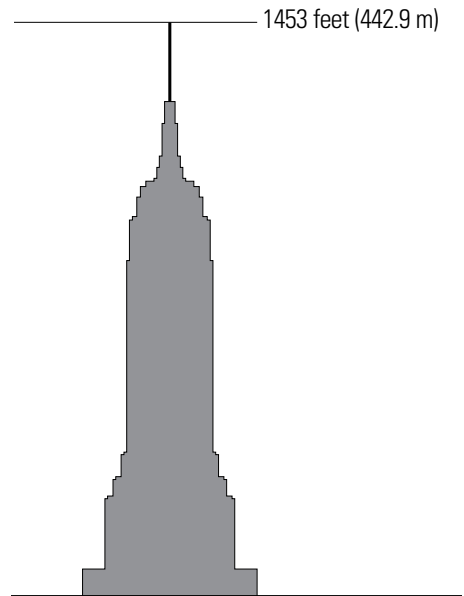

1931: Empire State Building, New York City, Shreve, Lamb, and Harmon. World's tallest building until 1972.

1940

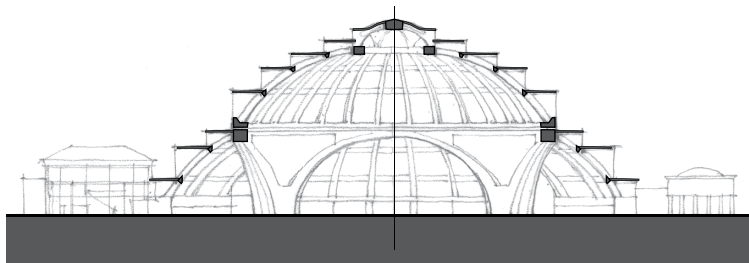

1913: Jahrhunderthalle (Centennial Hall), Breslau, Max Berg. Reinforced concrete structure, including a 213-foot (65-m) diameter dome, influences the use of concrete for enclosing large, public spaces.

With the advent of improved steels and computerized stress analytical techniques, steel structures have become lighter and joints more refined, allowing an array of structural shapes.

1903: Alexander Graham Bell experiments with spatial structural forms, leading to the later development of space frames by Buckminster Fuller, Max Mengerhausen, and Konrad Wachsmann.

1919: Walter Gropius establishes the Bauhaus.

1928: Eugène Freyssinet invents prestressed concrete.

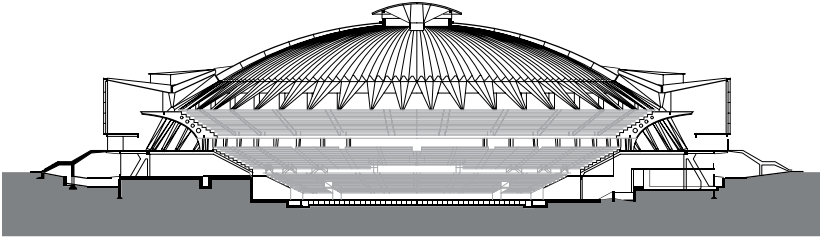

1960: Palazzo Dello Sport, Rome, Italy, Pier Luigi Nervi. 330-foot (100-m) diameter ribbed reinforced-concrete dome built for the 1960 Summer Olympic Games.

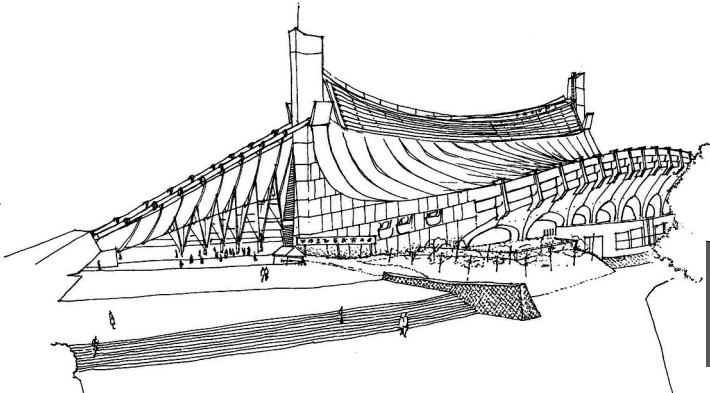

1961: Olympic Arena, Tokyo, Kenzo Tange. World's largest suspended roof structure when built, its steel cables are suspended from two reinforced concrete pillars.

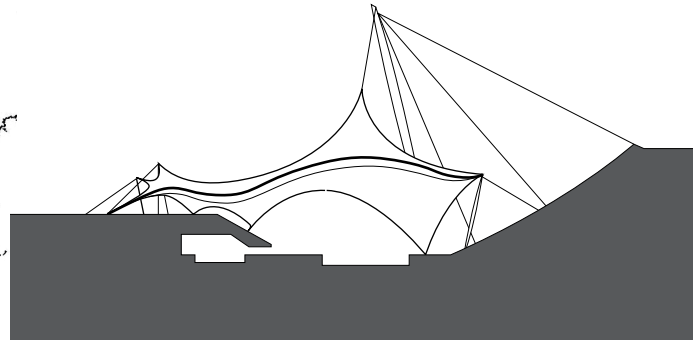

1972: Olympic Swimming Arena, Munich, Germany, Frei Otto. Steel cables combine with fabric membranes to create an extremely lightweight, long-span structure.

1950

1975

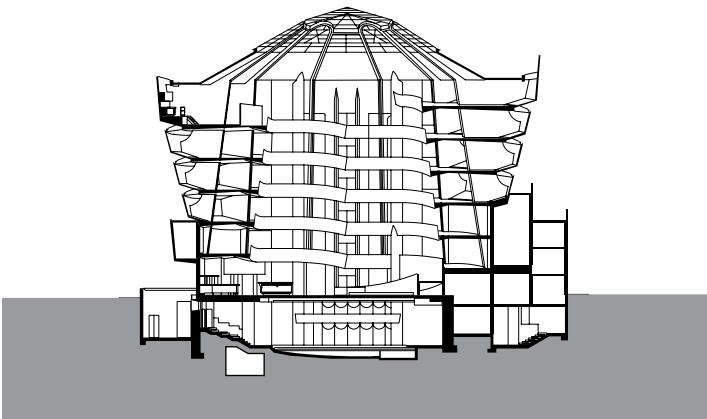

1943–59: Guggenheim Museum, New York City, Frank Lloyd Wright.

1955: The commercial use of computers develops.

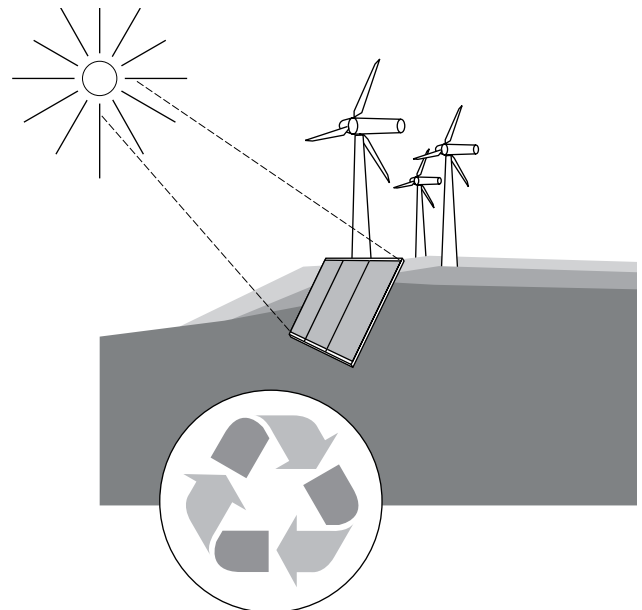

1973: Rise in oil prices stimulates research into alternative sources of energy, leading to energy conservation becoming a major element in architectural design.

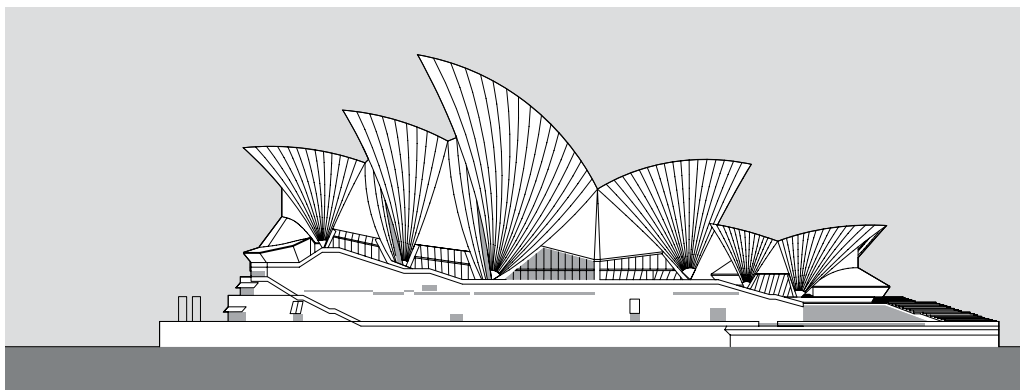
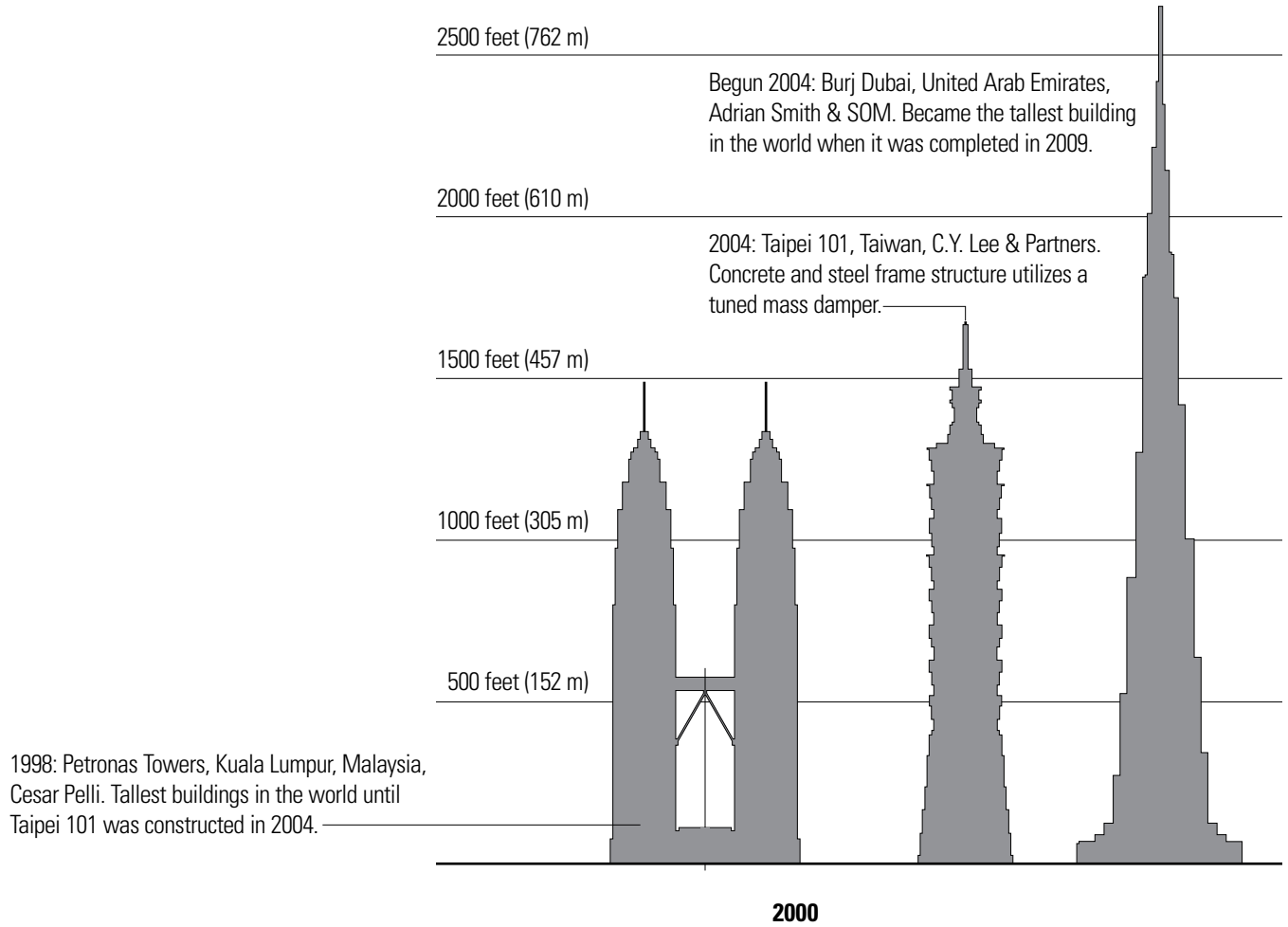

1973: Sydney Opera House, Jørn Utzon. Iconic shell structures consist of prefabricated, cast-on-site concrete ribs.

ARCHITECTURAL STRUCTURES

The preceding historical review conveys a sense not only of how structural systems have evolved but also how they have had, and will continue to have, an impact on architectural design. Architecture embodies ineffable yet sensible, aesthetic qualities that emerge from a union of space, form, and structure. In providing support for other building systems and our activities, a structural system enables the shape and form of a building and its spaces, similar to the way in which our skeletal system gives shape and form to our body and support to its organs and tissues. So when we speak of architectural structures, we refer to those that unite with form and space in a coherent manner.

Designing an architectural structure therefore involves more than the proper sizing of any single element or component, or even the design of any particular structural assembly. It is not simply the task of balancing and resolving forces. Rather, it requires that we consider the manner in which the overall configuration and scale of structural elements, assemblies, and connections encapsulate an architectural idea, reinforce the architectural form and spatial composition of a design proposal, and enable its constructibility. This then requires an awareness of structure as a system of interconnected and interrelated parts, an understanding of the generic types of structural systems, as well as an appreciation for the capabilities of certain types of structural elements and assemblies.

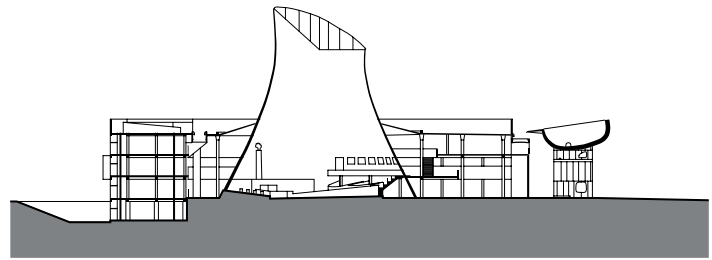

Section

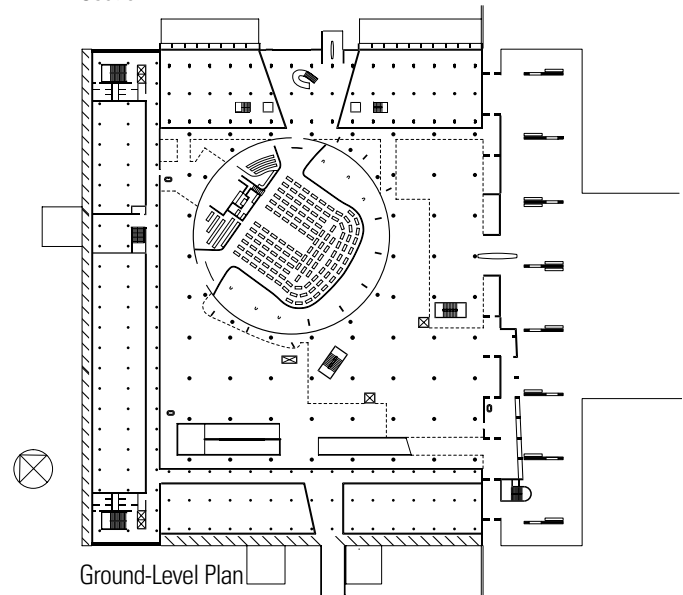

Ground-Level Plan

Parliament Building, Chandigarh, India, 1951–1963, Le Corbusier

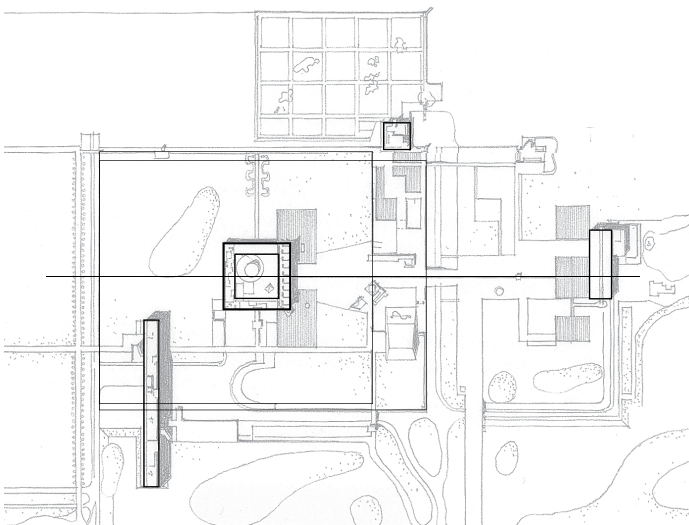

Site and Context

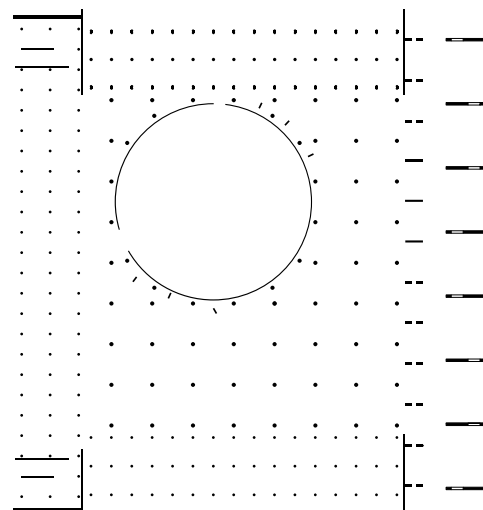

Structural Plan

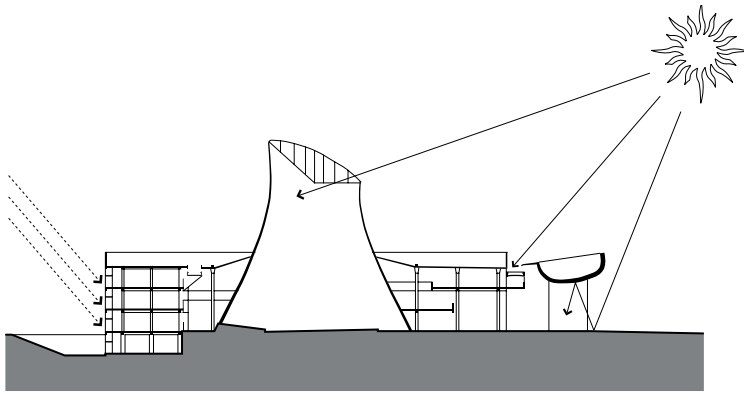

Natural Lighting

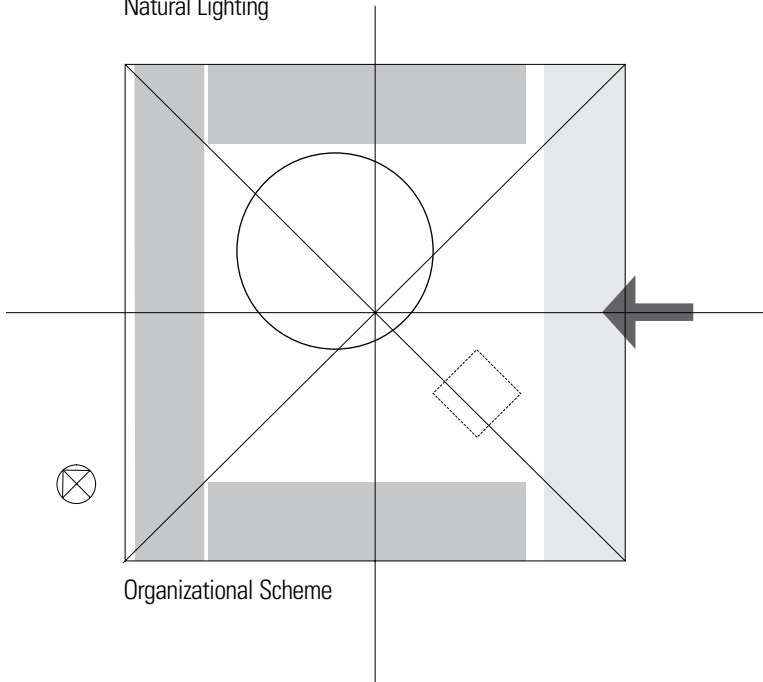

Organizational Scheme

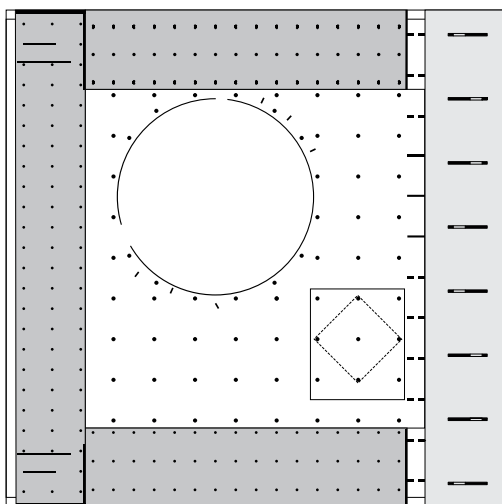

Structure Supporting Organizational Idea

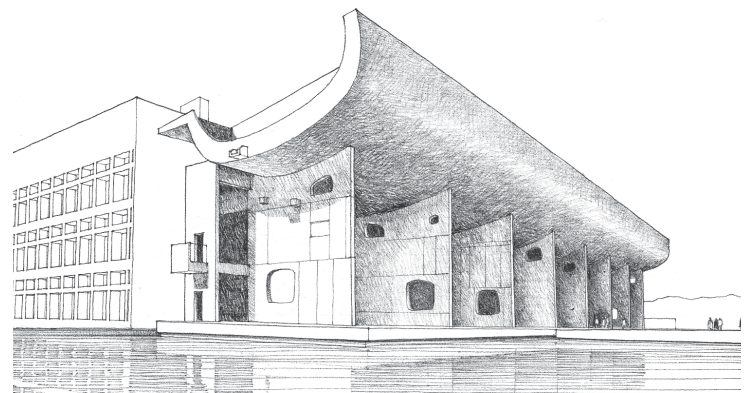

Structure Supporting Formal Idea

To understand the impact of structural systems on architectural design, we should be aware of how they relate to the conceptual, experiential, and contextual ordering of architecture.

- Formal and spatial composition
- Definition, scale, and proportions of forms and spaces
- Qualities of shape, form, space, light, color, texture, and pattern
- Ordering of human activities by their scale and dimension
- Functional zoning of spaces according to purpose and use
- Access to and the horizontal and vertical paths of movement through a building
- Buildings as integral components within the natural and built environment
- Sensory and cultural characteristics of place

The remaining sections of this chapter outline major aspects of structural systems that support, reinforce, and ultimately give form to an architectural idea.

ARCHITECTURAL STRUCTURES

Formal Intent

There are three fundamental ways in which the structural system can relate to the form of an architectural design. These fundamental strategies are:

- Exposing the structural system
- Concealing the structure
- Celebrating the structure

Exposing the Structure

Historically, stone- and masonry-bearing wall systems dominated architecture until the advent of iron and steel construction in the late-18th century. These structural systems also functioned as the primary system of enclosure and therefore expressed the form of the architecture, typically in an honest and straightforward manner.

Whatever formal modifications were made were usually a result of molding or carving the structural material in such a way as to create additive elements, subtractive voids, or reliefs within the mass of the structure.

Even in the modern era, there are examples of buildings that exposed their structural systems—whether in timber, steel, or concrete—using them effectively as the primary architectural form-givers.

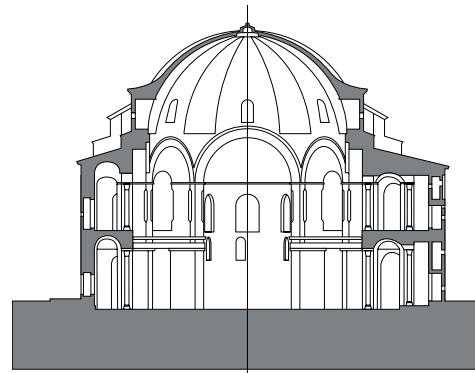

Section

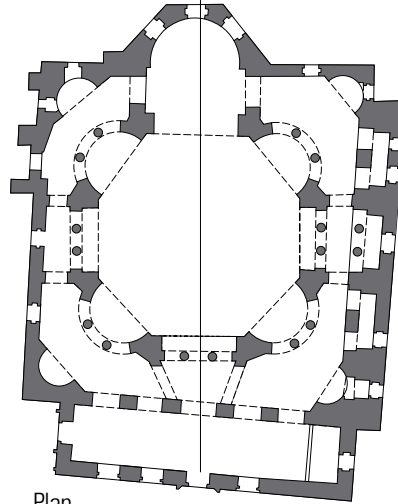

Plan

SS. Sergius and Bacchus, Istanbul, Turkey, 527–536 AD. The Ottomans converted this Eastern Orthodox church into a mosque. Featuring a central dome plan, it is believed by some to be a model for Hagia Sophia.

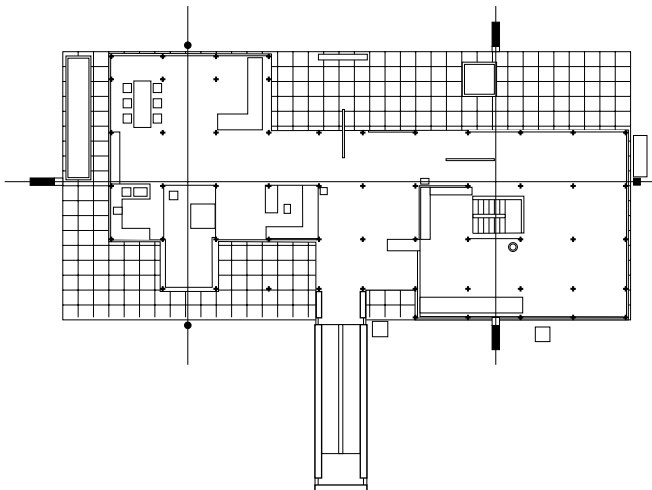
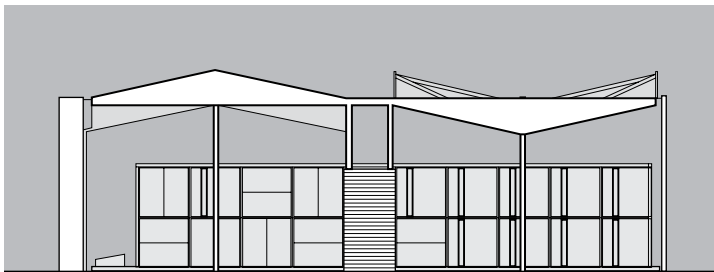

Centre Le Corbusier/Heidi Weber Pavilion, Zurich, 1965, Le Corbusier. A structural steel parasol hovers over a modular steel frame structure with sides of enameled steel panels and glass.

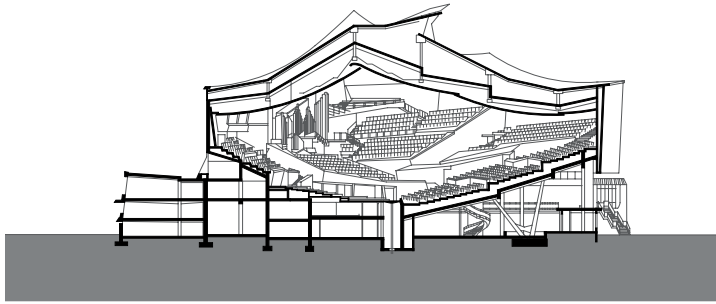

Section

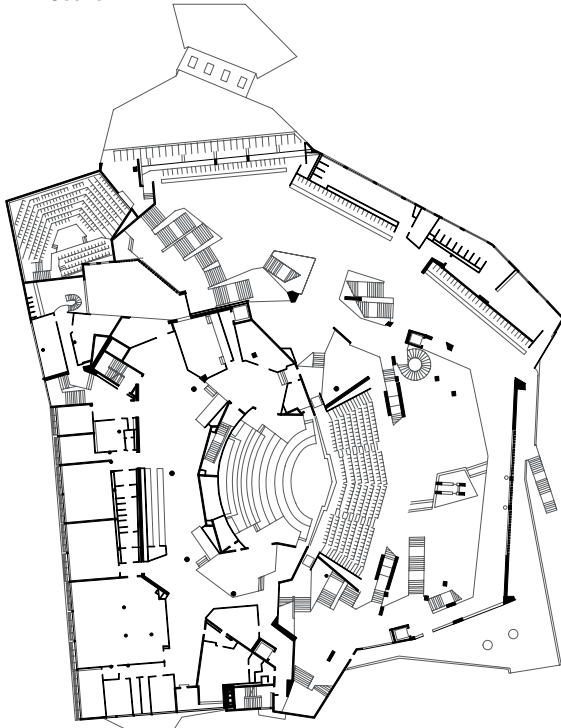

Lower-Level Plan

Concealing the Structure

In this strategy, the structural system is concealed or obscured by the exterior cladding and roofing of the building. Some reasons for concealing the structure are practical, as when the structural elements must be clad to make them fire-resistant, or contextual, as when the desired exterior form is at odds with interior space requirements. In the latter case, the structure may organize the interior spaces while the form of the exterior shell responds to site conditions or constraints.

The designer may simply want freedom of expression for the shell without considering how the structural system might aid or hinder formal decisions. Or the structural system may be obscured through neglect rather than intent. In both of these cases, legitimate questions arise as to whether the resulting design is intentional or accidental, willful or, dare we say, careless.

◀ Philharmonic Hall, Berlin, Germany, 1960–63, Hans Scharoun. An example of the Expressionist movement, this concert hall has an asymmetric structure with a tent-like concrete roof and a stage in the middle of terraced seating. Its external appearance is subordinate to the functional and acoustic requirements of the concert hall.

Guggenheim Museum, Bilbao, Spain, 1991–97, Frank Gehry. A novelty when completed, this contemporary art museum is known for its sculpted, titanium-clad forms. While difficult to understand in traditional architectural terms, the definition and constructibility of the apparently random forms were made possible through the use of CATIA, an integrated suite of Computer Aided Design (CAD), Computer Aided Engineering (CAE), and Computer Aided Manufacturing (CAM) applications.

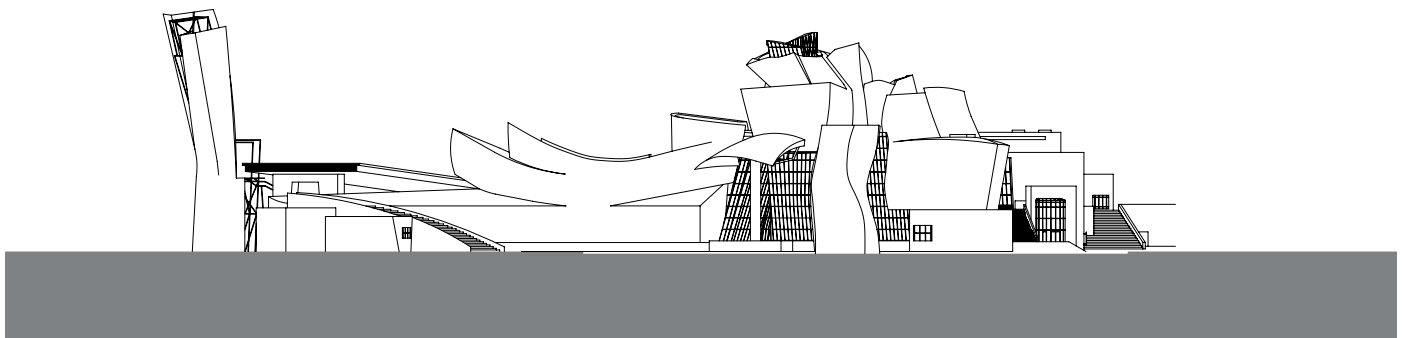

ARCHITECTURAL STRUCTURES

Celebrating the Structure

Rather than being merely exposed, the structural system can be exploited as a design feature, celebrating the form and materiality of the structure. The often exuberant nature of shell and membrane structures makes them appropriate candidates for this category.

There are also those structures that dominate by the sheer forcefulness with which they express the way they resolve the forces acting on them. These types of structures often become iconic symbols due to their striking imagery. Think Eiffel Tower or the Sydney Opera House.

When judging whether a building celebrates its structure or not, we should be careful to differentiate structural expression from expressive forms which are not, in truth, structural but only appear to be so.

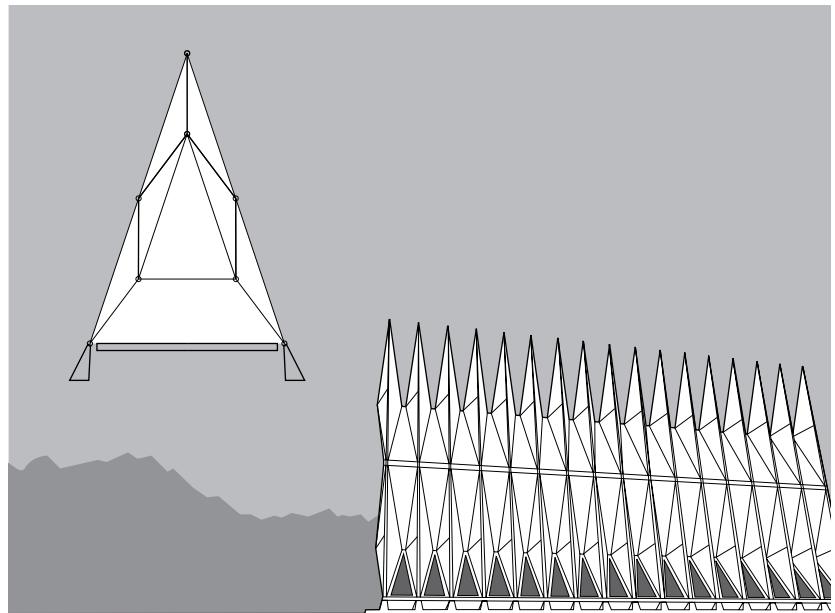

Air Force Academy Chapel, Colorado Springs, Colorado, USA, 1956–62, Walter Netsch/Skidmore, Owings and Merrill. The soaring structure, consisting of 100 identical tetrahedrons, develops stability through the triangulation of individual structural units as well as a triangular section.

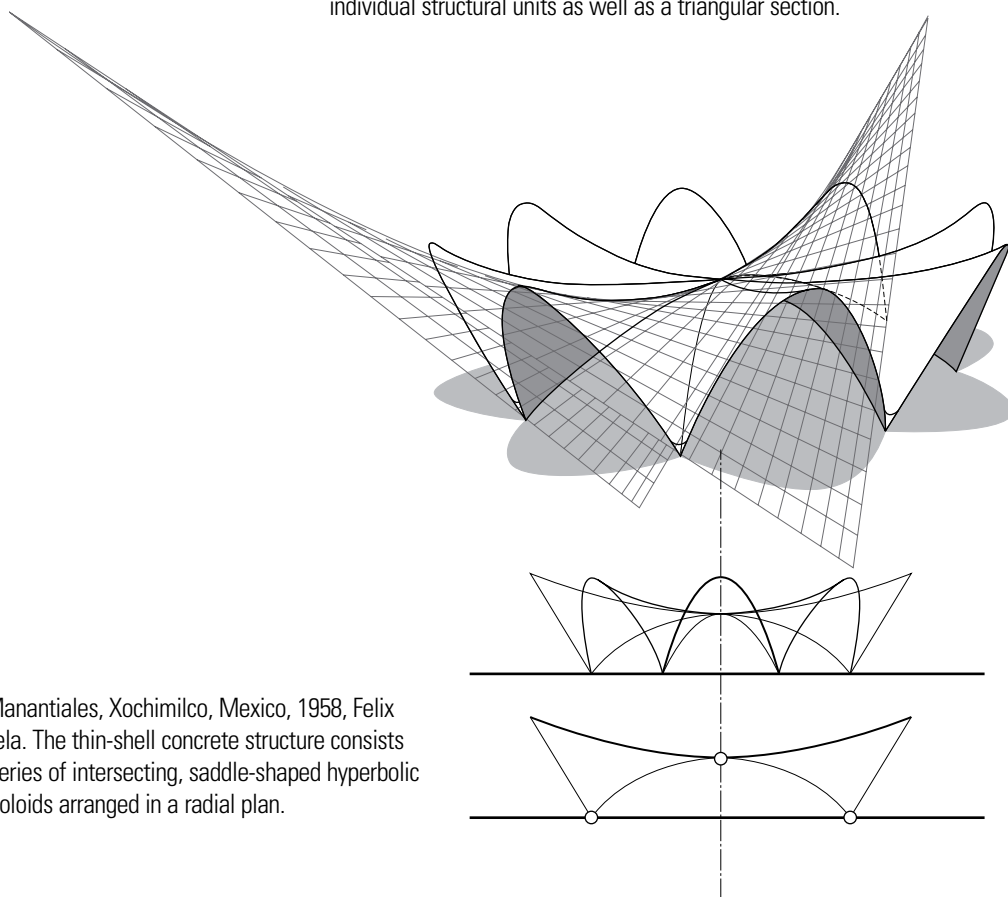

Los Manantiales, Xochimilco, Mexico, 1958, Felix Candela. The thin-shell concrete structure consists of a series of intersecting, saddle-shaped hyperbolic paraboloids arranged in a radial plan.

Main Terminal, Dulles International Airport, Chantilly, Virginia, USA, 1958–62, Eero Saarinen. Catenary cables suspended between two long colonnades of outward-leaning and tapered columns carry a gracefully curved concrete roof suggestive of flight.

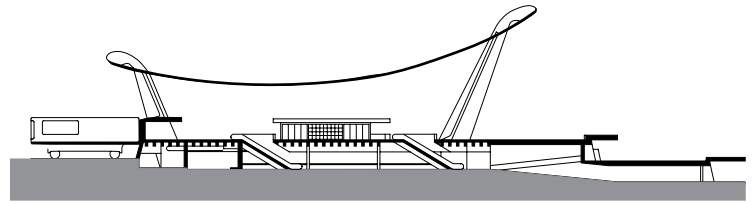

Hong Kong and Shanghai Bank, Hong Kong, China, 1979–85, Norman Foster. Eight groups of four aluminum-clad steel columns rise up from the foundations and support five levels of suspension trusses, from which are hung the floor structures.

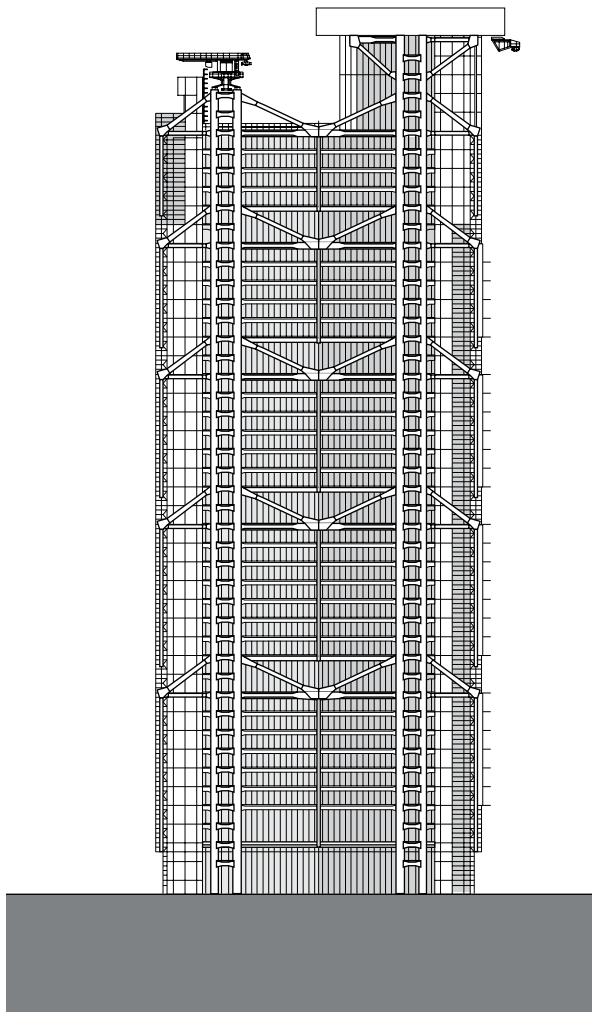

Elevation and Structural Plan

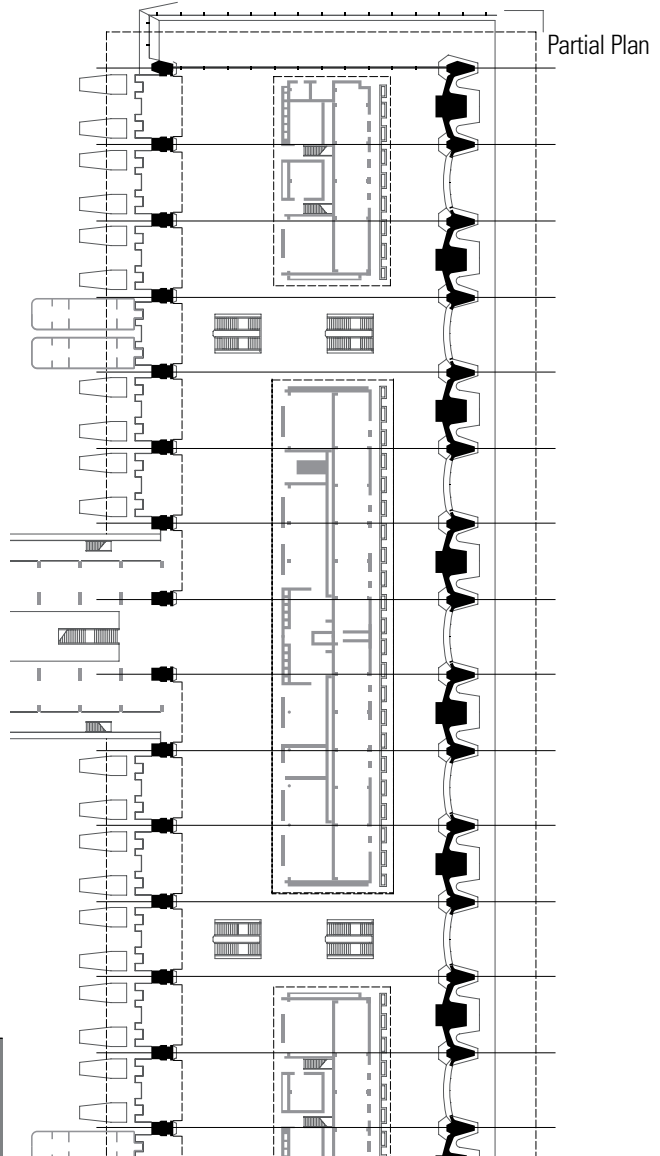
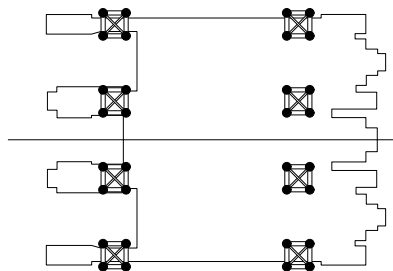

Partial Plan

ARCHITECTURAL STRUCTURES

Spatial Composition

The form of a structural system and the pattern of its supporting and spanning elements can be related to the spatial layout and composition of a design in two fundamental ways. The first is a correspondence between the form of the structural system and that of the spatial composition. The second is a looser fit in which the structural form and pattern allow more freedom or flexibility in spatial layout.

Correspondence

Where there is a correspondence between structural form and spatial composition, either the pattern of structural supports and spanning systems can prescribe the disposition of spaces within a building or the spatial layout can suggest a certain type of structural system. In the design process, which comes first?

In ideal cases, we consider both space and structure together as co-determinants of architectural form. But composing spaces according to needs and desires often precedes thinking about structure. On the other hand, there are times when structural form can be the driving force in the design process.

In either case, structural systems that prescribe a pattern of spaces of certain sizes and dimensions, or even a pattern of use, may not allow for flexibility in future use or adaptation.

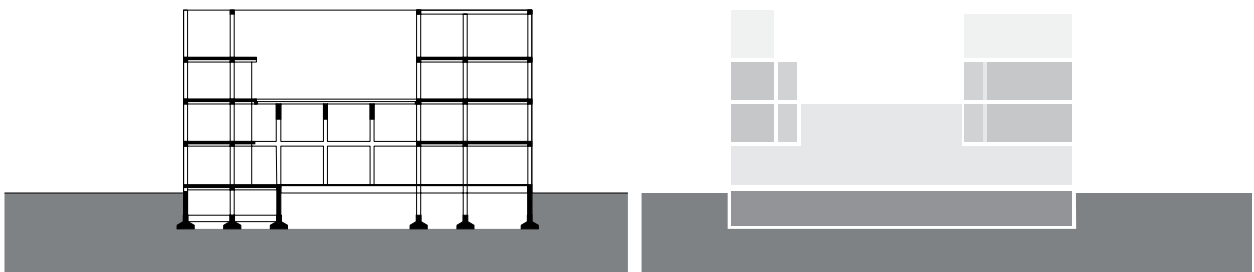
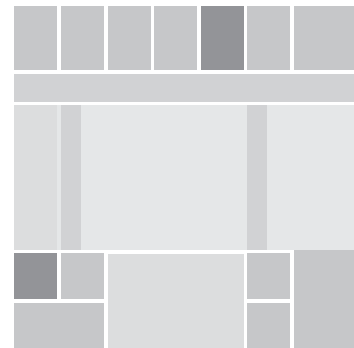
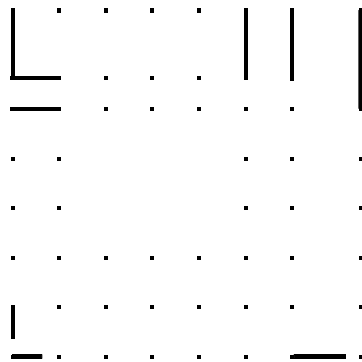
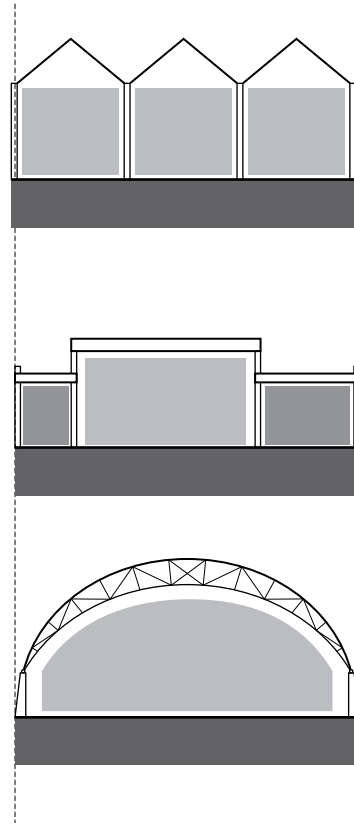

Structural and Spatial Diagrams in Plan and Section. Casa del Fascio, Como, Italy, 1932–36, Giuseppe Terragni.